

**N6.2400 G-E**  
**N6.2900 G-E**  
**N7.3600 G-E**  
**N7.4500 G-E**

# elco

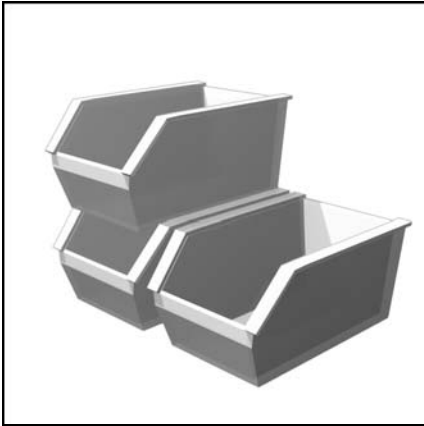

**Ersatzteilliste**  
**Pièces de rechange**  
**Parti ricambi**  
**Wisselstukkenlijst**  
**Spare parts list**  
**Запчасти**  
**Piezas de recambio**  
**Części zamienne**  
**Yedek parçalar**  
**Peças de substituição**



Pos.	Art. Nr.
500	N6.2400/2900 KN
	N6.2400/2900 KM
	N6.2400/2900 KL
511	N7.3600/4500 KN
	N7.3600/4500 KM
	N7.3600/4500 KL
512	N6/7.2400/4500 KN/KL
513	N6/7.2400/4500 KN/KL
514	N6/7.2400/4500 KN/KL
515	N6/7.2400/4500 KN/KL
516	N6/7.2400/4500 KN/KL
517	N6/7.2400/4500 KN/KL
520	N6/7.2400/4500 KN/KL
530	N6.2400/2900 KN
	N6.2400/2900 KM
	N6.2400/2900 KL
550	N7.3600/4500 KN
	N7.3600/4500 KM
	N7.3600/4500 KL
550	N6/7.2400/4500 KN/KL

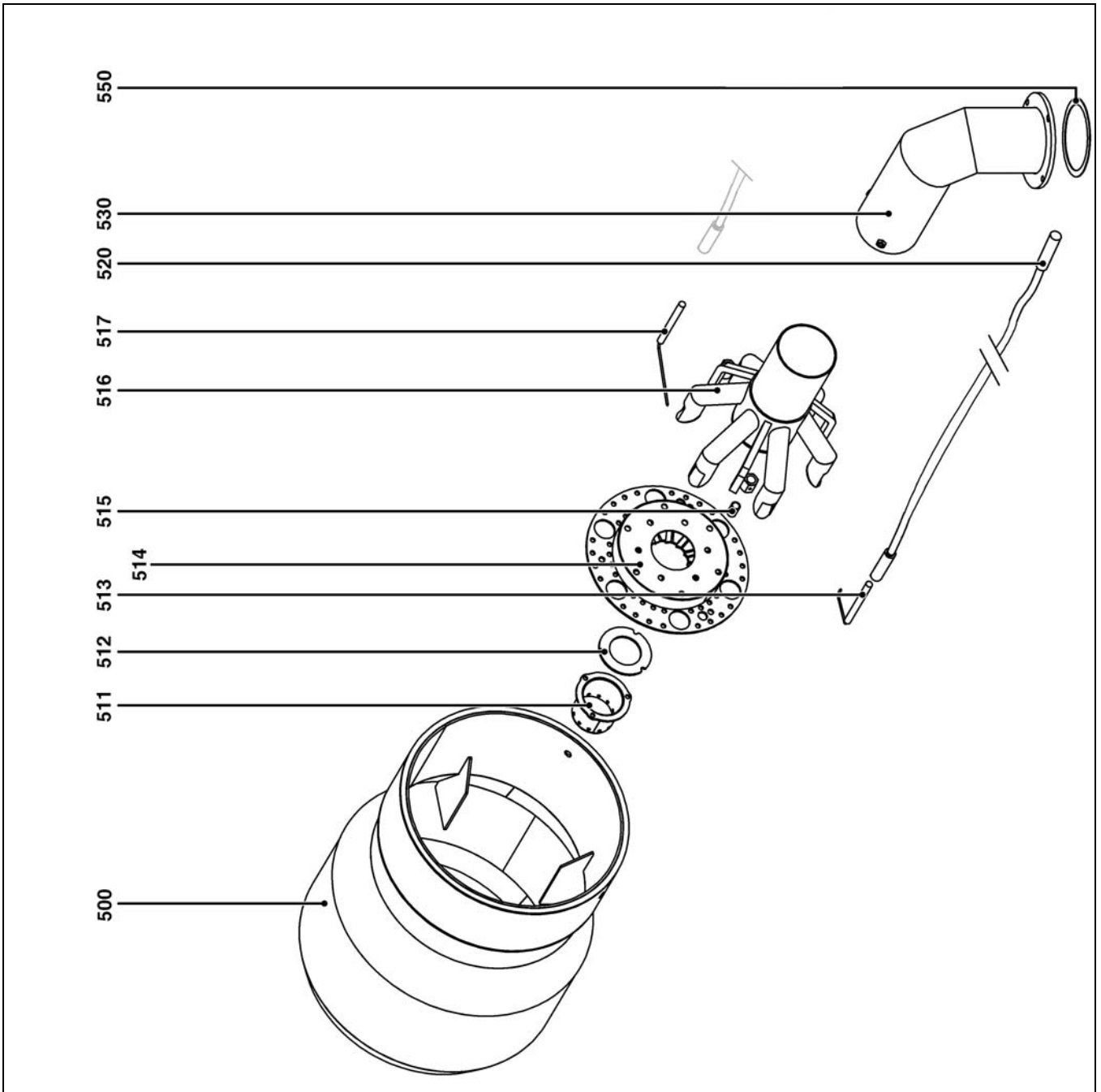

Pos.	Bezeichnung	Désignation	Descrizione	Naam	Description
500	Flammrohr	Tube du brûleur	Tubo del bruciatore	Branderbuis	Burner tube
511	Düsenkopf	Diffuseur	Diffusore	Verspreider	Diffuser
512	Dichtung	Joint	Guarnizione	Afdichting	Seal
513	Gaszündelektrode	Electrode d'allumage	Elettrodo di accensione	Ontstekingselektrode	Ignition electrode
514	Stauscheibe	Défecteur	Deflettore	Geleideplaat	Baffle plate
515	Spannhülse	Bague de serrage	Anello di serraggio	Vastzetbus	Clamping ring
516	Gaskopfaufsatz	Etoile gaz	Stella gas	Gasster	Star gas head
517	Ionisationselektrode	Sonde ionisation	Sonda di ionizzazione	Ionisatiesensor	Ionisation probe
520	Zündkabel kpl.	Câble d'allumage	Cavo di accensione	Ontstekingskabel	Ignition lead
530	Gaskopf, Basisrohr	Tube d'aménée gaz + coude	Tube di portata gas + gomito	Gasvoerbuis + bocht	Gas inlet tube + elbow
550	Dichtung	Joint	Guarnizione	Afdichting	Seal



Pos.		Art. Nr.
550	N6/7.2400/4500	65311 476
551	N6/7.2400/4500	65311 617
552	N6/7.2400/4500	65311 478
553	N6.2400/2900	65311 490
	N7.3600/4500	65311 474
556	N6/7.2400/4500	118 060 3227
557	N6/7.2400/4500	118 805 2260
558	N6/7.2400/4500	118 055 9591
559	N6/7.2400/4500	65311 471
560	N6/7.2400/4500	65311 472
561	N6/7.2400/4500	65311 595
563	N6/7.2400/4500 BT3xx	--
	Etamatic	65312 487
566	N6/7.2400/4500 BT3xx	65311 650
	Etamatic	65311 833
567	N6.2400	65311 824
	N6.2900	65311 825
	N7.3600	65311 353
	N6.4500	65311 826
568	N6/7.2400/4500	65311 502
570	N6/7.2400/4500	65311 477
573	N6/7.2400/4500	65311 512
576	N6.2400	65311 500
	N6.2900	65311 489
	N7.3600	65311 473
	N6.4500	65311 501
577	N6/7.2400/4500	65311 544
579	N6.2400/2900 N7.3600/4500	65311 827 65311 828

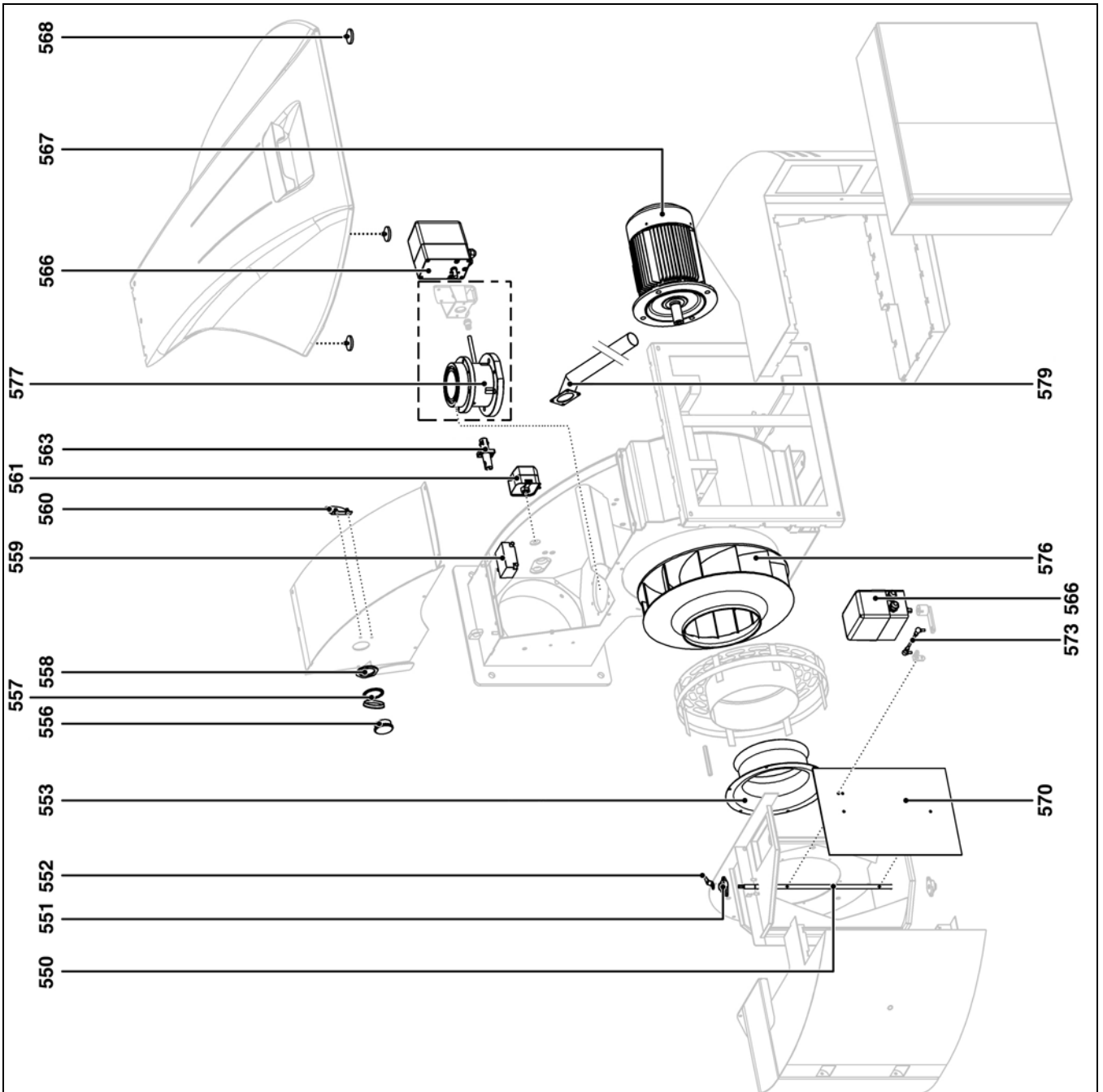

Pos.	Bezeichnung	Désignation	Descrizione	Naam	Description
550	Luftklappenwelle	Axe volet	Asse serranda	Klepas	Flap axis
551	Flanschlager	Palier	Cuscinetto	Lager	Bearing
552	Verstellanzeiger Luftklappe	Lévrier volet air	Leva serranda aria	Hendel luchtklep	Air flap lever
553	Ansaugtrichter	Entrée d'air	Convogliatore dell'aria	Luchtinlaat	Air inlet
556	Schauglas	Voyant	Spia	Kijkglas	Indicator light
557	Schauglasdeckel	Cache voyant	Coperchio spia	Afdeksplaatje Kijkglas	Indicator light cover
558	Schauglasmutter	Ecrou voyant	Dado spia	Moer kijkglas	Indicator light nut
559	Zündtrafo	Allumeur	Accenditore	Ontsteker	Igniter
560	Sichtspiegel für Schauglas	Miroir du voyant	Specchio della spia	Spiegel van kijkglas	Indicator light mirror
561	Luftdruckwächter	Manostat d'air	Pressostato aria	Luchtdrukbewaker	Air pressure switch
563	Flammenwächter	Surveillance de flamme	Sorveglianza della fiamma	Vlambewaker	Flame monitoring
566	Stellantrieb Luft und Gas	Servomoteur air et gaz	Servomotore aria e gas	Servomotor lucht en gas	Air and gas servomotor
567	Motor	Moteur	Motore	Motor	Motor
568	Magnet für Haube	Aimant de fixation capot	Magnete di fissaggio coperchio	Kapbevestigingsmagneet	Hood mounting magnet
570	Luftklappe	Volet d'air	Serranda aria	Luchtklep	Air flap
573	Winkelgelenkstange	Biellette volet d'air	Bielletta serranda aria	Stangetje luchtklep	Air flap lever
576	Ventilatorrad	Turbine	Turbina	Turbine	Turbine
577	Gasklappe kpl	Clapet gaz assemblé	Valvola gas montata	Gasklep geassembleerd	Assembled gas throttle
579	Anschlussstück für Kühlung FU	Tube de refroidissement du variateur	Tube per raffreddamento del variatore	Buis voor koeling van de frequentie omvormer	Cooling tube for frequency controller



Pos.		Art. Nr.
3010	N6/7.2400/4500-Rp1½"	65311 503
	N6/7.2400/4500-Rp2"	65311 488
3020	N6/7.2400/4500	65311 606
3030	N6/7.2400/4500	65311 604
3040	N6/7.2400/4500	65311 579
3060	N6/7.2400/4500-Rp1½"	65311 580
	N6/7.2400/4500-Rp2"	65311 581
3070	N6/7.2400/4500	65107 100
3080	N6/7.2400/4500	65311 585
3090	N6/7.2400/4500	147 883 6180
3110	N6/7.2400/4500-Rp1½"	65313 107
	N6/7.2400/4500-Rp2"	65311 377
3120	N6/7.2400/4500	
	GW500 A5 (30-500 mbar)	13010 091
	GW150 A6 (Option)	65311 597
3130	N6/7.2400/4500	65311 586
3140	N6/7.2400/4500	65311 615
3300	Rp1½"	65311 458
	Rp2"	65311 459
	DN65	65311 460
	DN80	65311 461
3301	Rp1½"	65311 361
	DN65	65311 723
	DN80	65311 888
5010	N6/7.2400/4500	65311 362

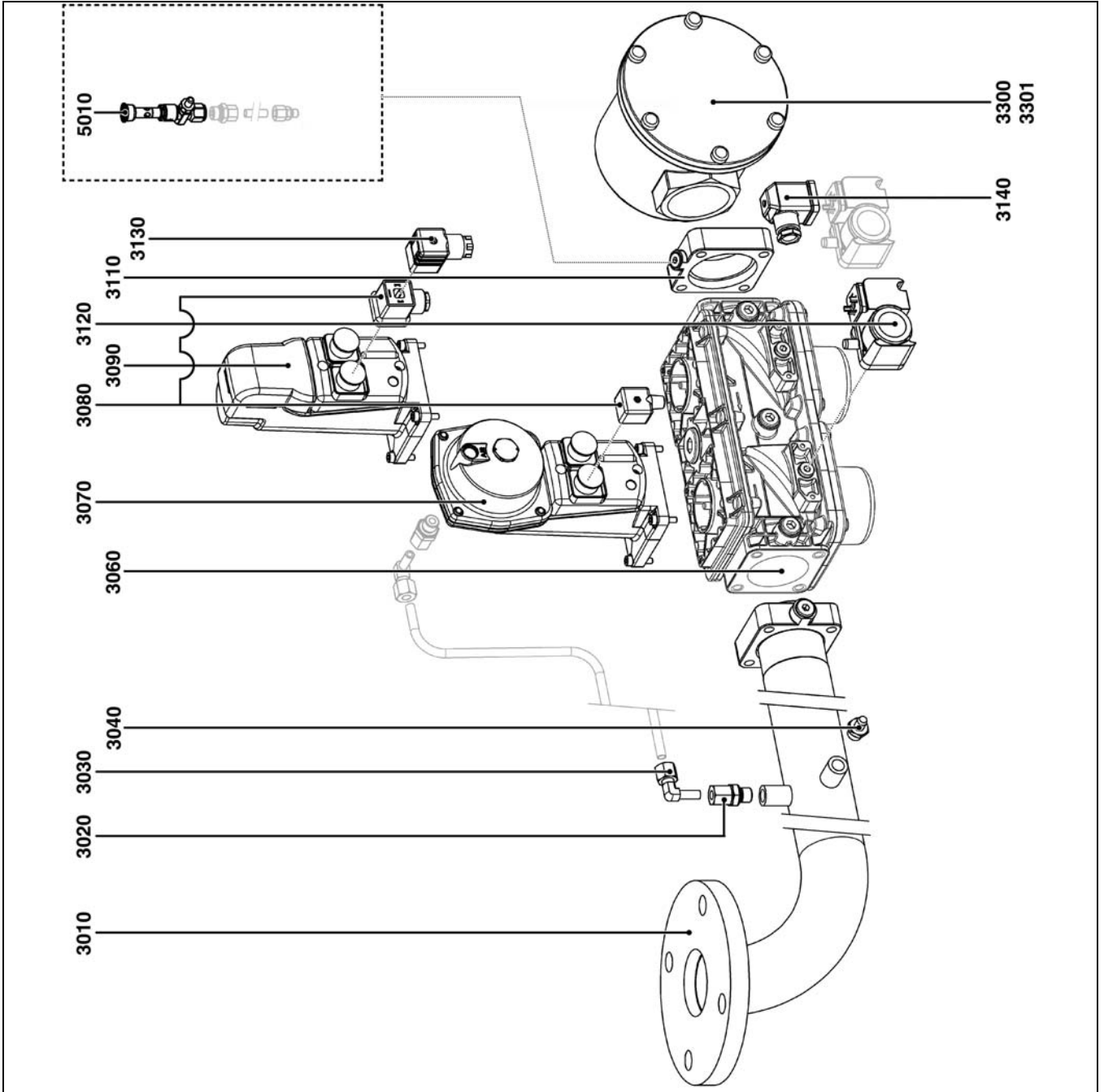

Pos.	Bezeichnung	Désignation	Descrizione	Naam	Description
3010	Gasanschlussstück	Collecteur gaz	Collettore gas	Gasspruitstuk	Gas collector
3020	Gerade-Einschraubstut.	Raccord droit	Raccordo destro	Rechte aansluiting	Straight union
3030	Einstellbare Winkelverschraubung	Raccord coudé orientable	Raccordo a gomito orientabile	Gebogen draaibare aansluiting	Directable angled union
3040	Messnippel + Dichtung	Prise de pression + joint	Prisa di pressione + guarnizione	Drukaansluiting + afdichting	Pressure tap + seal
3060	Gasventil VGD	Vanne gaz VGD	Valvola gas VGD	Gasklep VGD	VGD gas valve
3070	Stellantrieb SKP 25	Régulateur SKP 25	Regolatore SKP 25	Regelaar SKP 25	SKP 25 regulator
3080	Zwischenstecker	Prise vannes	Prisa valvole	Kleppenaansluiting	Valve connector
3090	Stellantrieb SKP15	Régulateur SKP 15	Regolatore SKP 15	Regelaar SKP 15	SKP 15 regulator
3110	Anschlussflansch	Bride de raccordement	Fiangia di raccordo	Aansluitflens	Connecting flange
3120	Gasdruckwächter	Manostat gaz	Pressostato gas	Gasdruckbewaker	Gas pressure switch
3130	Leitungsdose Ventiltrieb	Prise vannes	Prisa valvole	Kleppenaansluiting	Valve connector
3140	Gerätesteckdose	Prise manostat	Prisa pressostato	Aansluiting druckbewaker	Pressure switch connector
3300	Gasfilter	Filtre	Filtro	Filter	Filter
3301	Ersatzteilset für Gasfilter	Kit cartouche filtrante	Set elemento filtrante	Set filterelement	Filter medium set
5010	Prüfbrenner mit Druckknopfahn	Brûleur de test avec robinet poussoir	Bruciatore di test con rubinetto a pulsante	Testbrander met indrukkraan	Test burner with shutting press button tap



Pos.	Art. Nr.
3510	Rp1"1/2 Rp2"
3580	Rp1"1/2 Rp2"
3620	Rp1"1/4 Rp1"1/2 Rp2"
3640	N6/7.2400/4500 GW500 A5 (30-500 mbar) GW150 A5 (Option)
3650	N6/7.2400/4500
3700	MBC 300 MBC 700 MBC 1200
3800	Rp1 1/2" Rp2" DN65 DN80
3801	Rp1 1/2" DN65 DN80
5010	N6/7.2400/4500

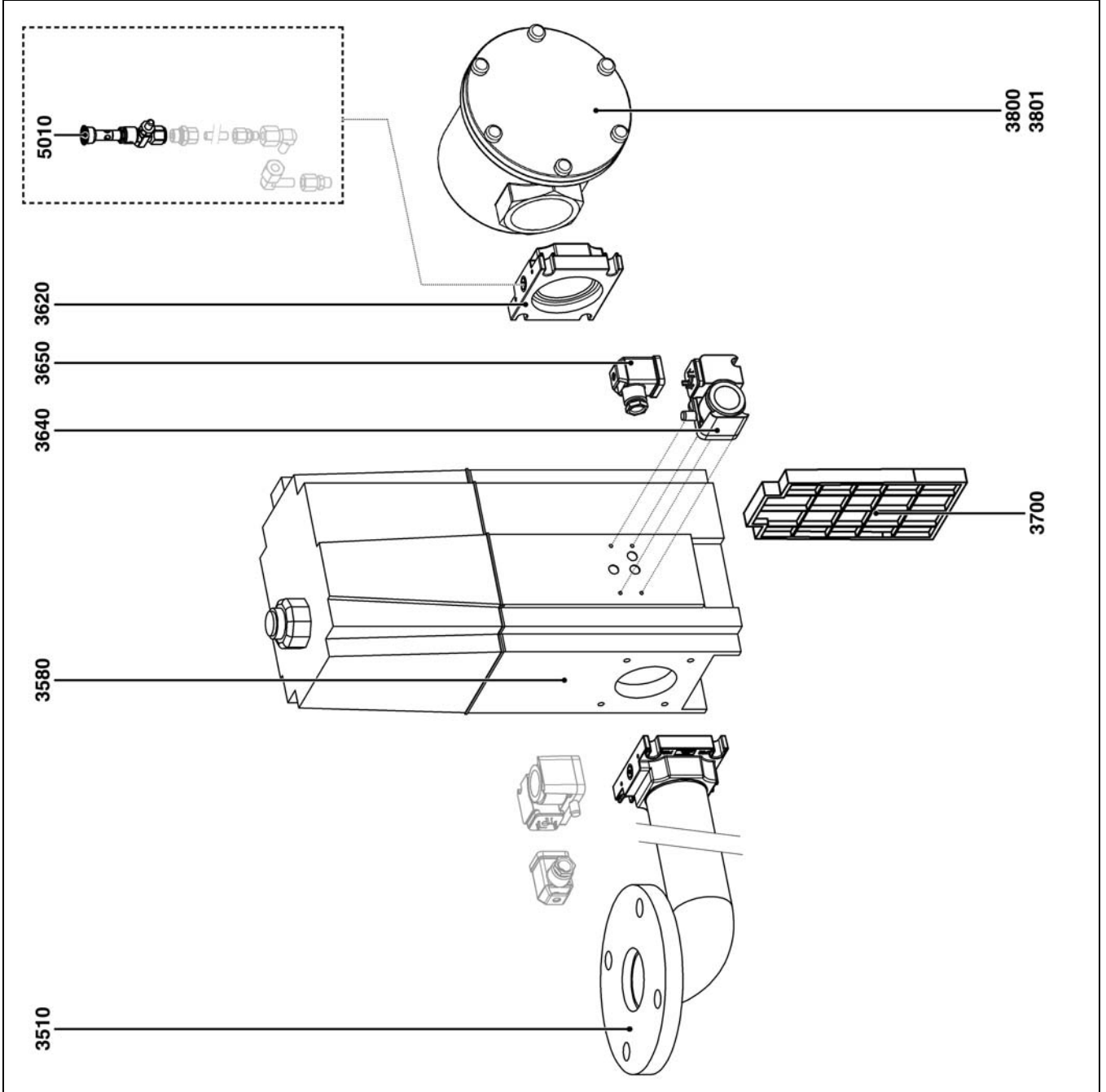

Pos.	Bezeichnung	Désignation	Descrizione	Naam	Description
3510	Gasanschlussstück	Collecteur	Collettore	Afscheider	Flange
3580	Gasventil	Vanne	Valvola	Klep	Solenoid valve
3620	Anschlussflansch	Bride	Flangia	Flens	Flange
3640	Druckwaechter	Manostat	Pressostato	Drukbewaker	Pressure switch
3650	Geraetesteckdose	Prise manostat	Presa pressostato	Stekker drukbewaker	Pressure switch connector
3700	Gasfilter / Ventil	Filtre / vanne	Filtro / valvola	Filter / klep	Filter / valve
3800	Gasfilter	Filtre	Filtro	Filter	Filter
3801	Ersatzteilset für Gasfilter	Kit cartouche filtrante	Set elemento filtrante	Set filterelement	Filter medium set
5010	Prüfbrenner mit Druckknopfhandh	Brûleur de test avec robinet poussoir	Bruciatore di test con rubinetto a pulsante	Testbrander met indrukdraan	Test burner with shutting press button tap



Pos.		Art. Nr.
4010	DN65 DN80 DN100 DN125	65311 506 65311 494 65311 508 65311 509
4020	N6/7.2400/4500	65311 601
4030	N6/7.2400/4500	65311 605
4040	N6/7.2400/4500	65311 603
4060	N6/7.2400/4500	65311 607
4080	DN65 DN80 DN100 DN125	65323 661 65311 583 65311 590 65311 543
4090	N6/7.2400/4500	65107 100
4100	N6/7.2400/4500	65311 585
4110	N6/7.2400/4500	147 883 6180
4120	DN65 DN80 DN100 DN125 DN150	65311 611 65311 612 65311 613 65311 614 65311 342
4130	N6/7.2400/4500	65311 586
4140	N6/7.2400/4500	65311 615
4150	N6/7.2400/4500 GW500 A5 (30-500 mbar) GW150 A6 (Option)	13010091 65311 597
4300	DN65 DN80 DN100 DN125 DN150	65311 460 65311 461 65311 462 65311 463 65311 892
4301	DN65 DN80 DN100 DN125 DN150	65311 723 65311 888 65311 889 65311 890 65311 623
5010	N8/9.5700/6500	65311 362

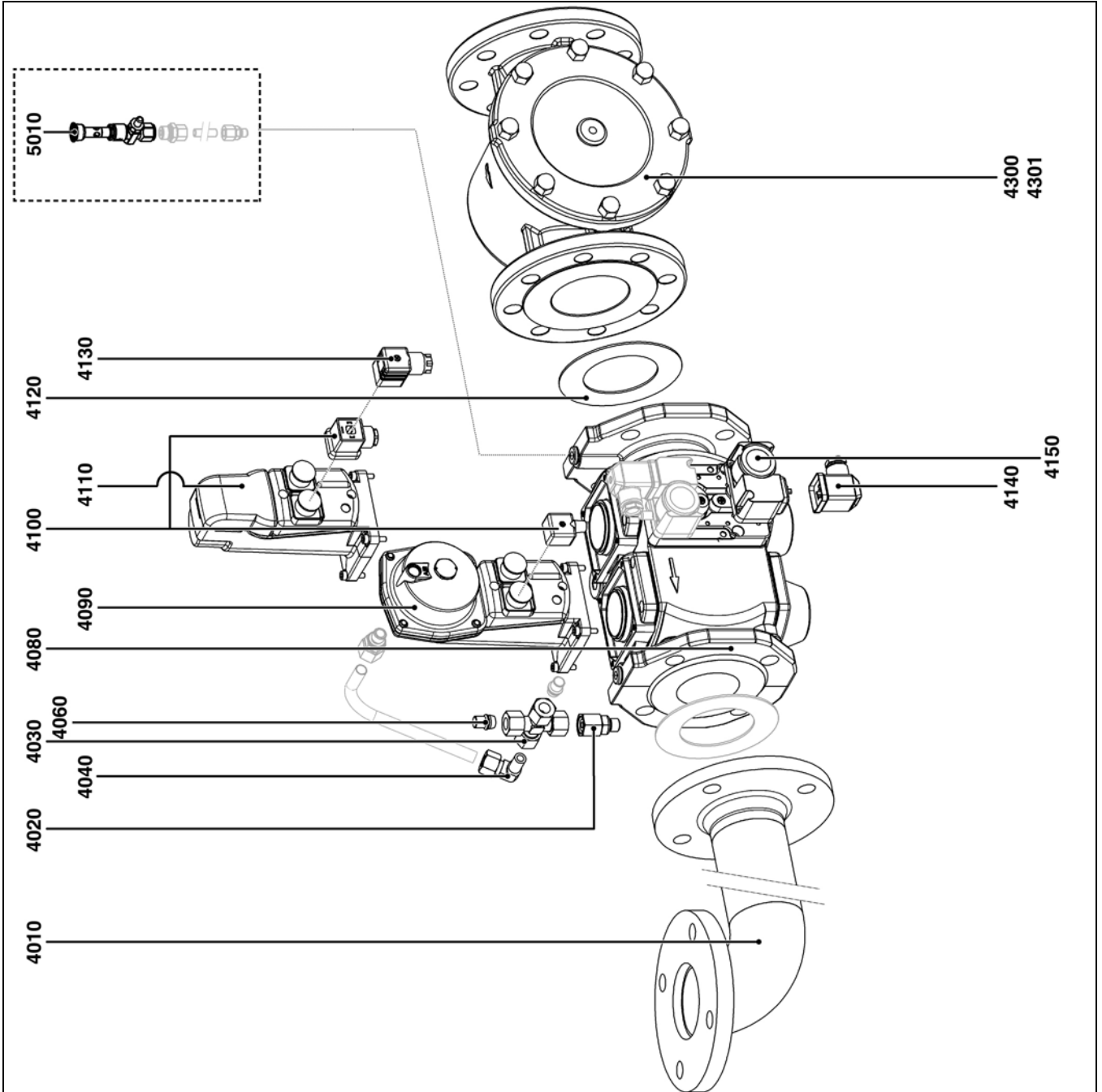

Pos.	Bezeichnung	Désignation	Descrizione	Naam	Description
4010	Gasanschlussstück	Collecteur gaz	Collettore gas	Gasspruitstuk	Gas collector
4020	Gerade-Einschraubstutze	Raccord droit	Raccordo destro	Rechte aansluiting	Straight union
4030	Kreuzverschr.	Raccord	Raccordo	Aansluiting	Union
4040	Einstellbare Winkelverschraubung	Raccord coudé orientable	Raccordo a gomito orientabile	Gebogen draaibare aansluiting	Directable angled union
4060	Verschlusstopfen	Bouchon	Tappo	Stop	Cap
4080	Gasventil VGD	Vanne gaz VGD	Valvola gas VGD	Gasklep VGD	VGD gas valve
4090	Stellantrieb SKP 25	Régulateur SKP 25	Regolatore SKP 25	Regelaar SKP 25	SKP 25 regulator
4100	Zwischenstecker	Prise vanne	Presa valvola	Kleppenaansluiting	Valve connector
4110	Stellantrieb SKP15	Régulateur SKP 15	Regolatore SKP 15	Regelaar SKP 15	SKP 15 regulator
4120	Dichtung	Joint	Guarnizione	Afdichting	Gasket
4130	Leitungsdose Ventiltrieb	Prise régulateur	Presa regolatore	Regelaaraansluiting	Regulator connector
4140	Gerätesteckdose	Prise manostat	Presa pressostato	Aansluiting drukkewaker	Pressure switch connector
4150	Gasdruckwächter	Manostat gaz	Pressostato gas	Gasdrukkewaker	Gas pressure switch
4300	Gasfilter	Filtre	Filtro	Filter	Filter
4301	Ersatzteilset für Gasfilter	Kit cartouche filtrante	Set elemento filtrante	Set filterelement	Filter medium set
5010	Prüfbrenner mit Druckknopfahnh	Brûleur de test avec robinet poussoir	Bruciatore di test con rubinetto a pulsante	Testbrander met indrukkraan	Test burner with shutting press button tap



Pos.		Art. Nr.
4510	DN65 DN80 DN100	65311 506 65311 494 65311 508
4520	N6/7.2400/4500	65311 601
4530	N6/7.2400/4500	65311 344
4560		65311 607
4580	DN65 DN80 DN100	65311 844 65311 845 65311 846
4620	DN65 DN80 DN100 DN125 DN150	65311 611 65311 612 65311 613 65311 614 65311 342
4640	N6/7.2400/4500 GW500 A5 (30-500 mbar) GW150 A6 (Option)	13010091 65311 597
4650	N6/7.2400/4500	65311 615
4800	DN65 DN80 DN100 DN125 DN150	65311 460 65311 461 65311 462 65311 463 65311 892
4801	DN65 DN80 DN100 DN125 DN150	65311 723 65311 888 65311 889 65311 890 65311 623
5010	N6/7.2400/4500	65311 362

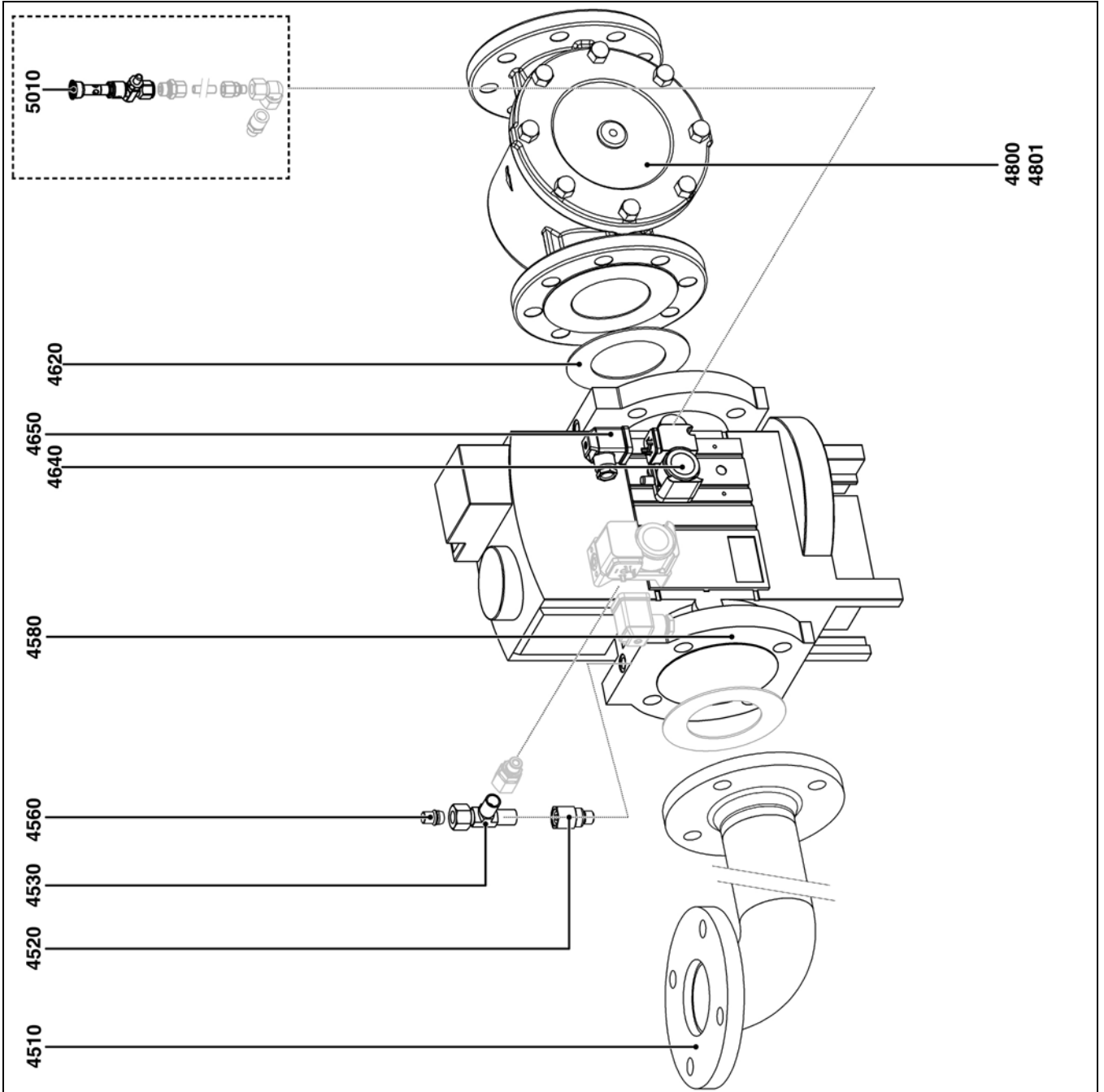

Pos.	Bezeichnung	Désignation	Descrizione	Naam	Description
4510	Gasanschlussstück	Collecteur	Collettore	Afscheider	Flange
4520	Gerade-Einschraubstut.	Raccord droit	Raccordo destro	Rechte aansluiting	Straight union
4530	Einstellbare Winkelverschraubung	Raccord orientable	Raccordo orientabile	Draaibare aansluiting	Directable union
4560	Verschlusstopfen	Bouchon	Tappo	Stop	Cap
4580	Gasventil	Vanne	Valvola	Klep	Solenoid valve
4620	Dichtung	Joint	Guarnizione	Afdichting	Gasket
4640	Druckwaechter	Manostat	Pressostato	Drukbewaker	Pressure switch
4650	Geraetesteckdose	Prise manostat	Presa pressostato	Stekker drukkewaker	Pressure switch connector
4800	Gasfilter	Filtre	Filtro	Filter	Filter
4801	Ersatzteilset für Gasfilter	Kit cartouche filtrante	Set elemento filtrante	Set filterelement	Filter medium set
5010	Prüfbrenner mit Druckknopfhandh	Brûleur de test avec robinet poussoir	Bruciatore di test con rubinetto a pulsante	Testbrander met indrukkraan	Test burner with shutting press button tap



Pos.		Art. Nr.
1610*	N6/N7	65 311 790
1640	N6/N7	65 311 446
1655	N6	65 311 793
	N7.3600	65 312 032
	N7.4500	65 311 947
1660	N6	65 311 794
	N7.3600	65 312 033
	N7.4500	65 311 776
1661	N6/N7	65 311 795
1665	N6/N7	65 311 919
1666	N6/N7	65 311 443
1667	N6/N7	65 311 444
1670	N6/N7 - CLED230	65 311 920
	N6/N7 - CK01	65 311 921
	N6/N7 - CK02	65 311 922
	N6/N7 - CK10	65 311 923
	N6/N7 - CK20	65 311 924
1675	N6/N7 - BT 320	65 312 451
	N6/N7 - BT 330*	65 312 446
1676	N6/N7 - BT 3xx	65 311 926
1680	N6/N7	65 311 927
1685	N6/N7	65 311 445
1690	N6/N7	65 311 449
1695	N6/N7	65 311 447
1700	N6/N7 - CLICK M16	65 311 451
	N6/N7 - CLICK M20	65 311 758
	N6/N7 - CLICK M25	65 311 759
1701	N6/N7 - CLICK M16	65 311 786
	N6/N7 - CLICK M20	65 311 787
	N6/N7 - CLICK M25	65 311 788
1705	N6/N7	65 311 443
1710	N6/N7	65 311 441
1715	N6/N7 - 10A	65 311 931
1716	N6/N7	65 311 932
1735	N6/N7	65 311 436
1740	N6/N7	65 311 437
1745	N6/N7	65 326 869
1750	N6/N7	65 311 364
1755	N6/N7	65 311 438
1760*	N6/N7	65 114 033

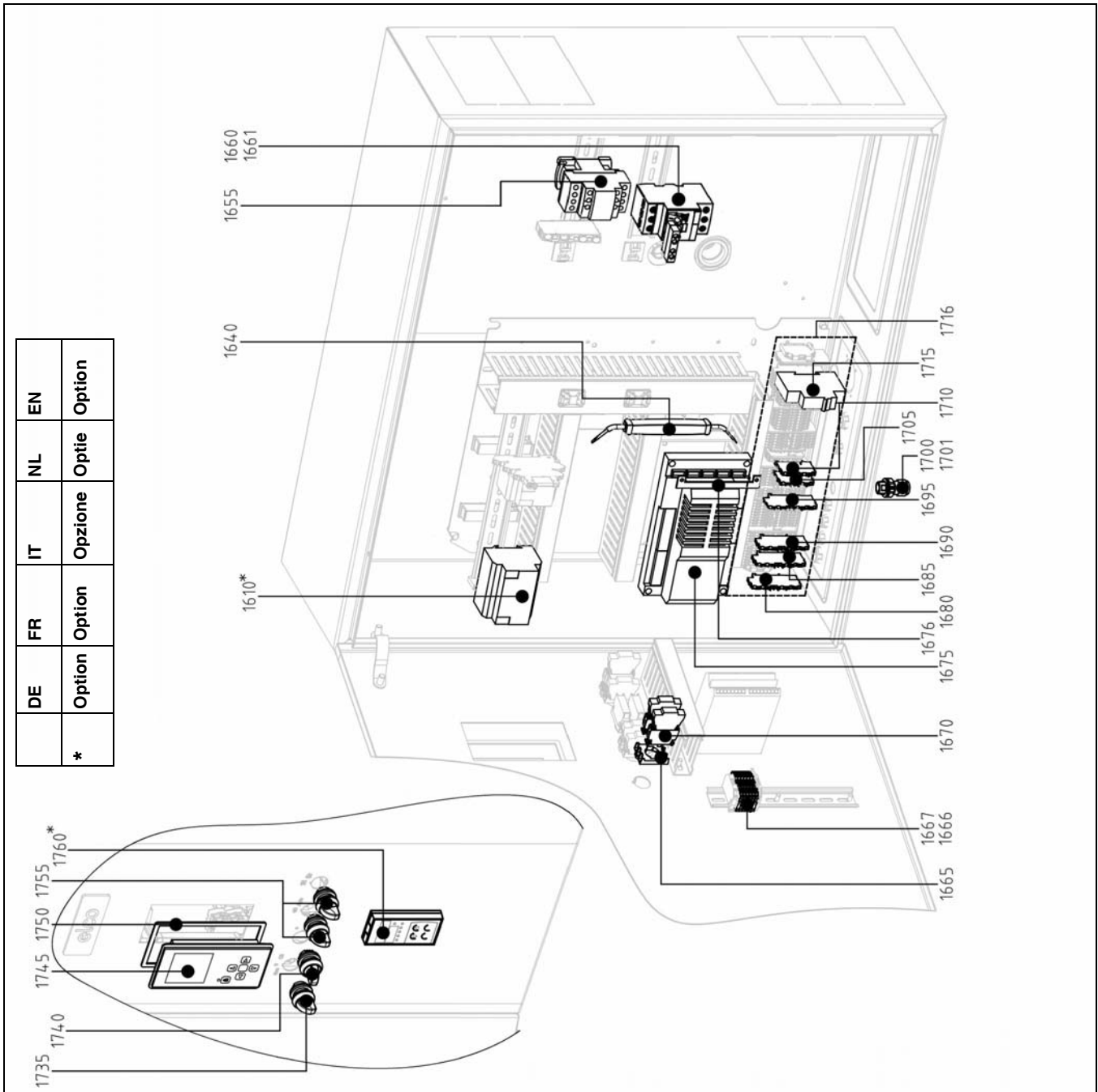

Pos.	Bezeichnung	Designation	Descrizione	Naam	Description
1610	LCM100-Modul	Module LCM100	Modulo LCM100	LCM100-module	LCM100 module
1636*	Netzteil	Transformateur	Trasformatore	Transformator	Transformer
1640	Betätigungswerkzeug	Outil de manoeuvre	Attrezzo di azionamento	Bedieningsgereedschap	Operating tool
1655	Motor Gebläse	Moteur Ventilateur	Motore ventilatore	Motor ventilator	Fan motor
1660	Motorschutzschalter Gebläse	Disjoncteur-protecteur de moteur Ventilateur	Interruttore di protezione motore ventilatore	Motorbeveiligingsschakelaar ventilator	Fan motor protection switch
1661	Hilfsschalter	Commutateur auxiliaire	Interruttore ausiliario	Hulpschakelaar	Auxiliary switch
1665	Geräteträger, 3-fach	Porte-outils triple	Supporto strumenti, triplo	Apparatenhouder, 3-voudig	Equipment rack, 3-tray
1666	Durchgangsklemme Grau	Borne de passage Gris	Morsetto passante grigio	Doorverbindingsklem grijs	Grey through terminal
1667	Durchgangsklemme PE	Borne de passage PE	Morsetto passante PE	Doorverbindingsklem PE	PE through terminal
1670	LED-Element, Weiss Öffner-Kontakt Offner-Doppel-Kontakt Schliesser-Kontakt Schliesser-Doppel-Kontakt	Élément LED, blanc Contact à ouverture Contact à double ouverture Contact à fermeture Contact à double fermeture	Elemento a LED, bianco Contatto di apertura Contatto a doppia apertura Contatto di chiusura Contatto a doppia chiusura	LED-element, wit Verbreekcontact Dubbel verbreekcontact Maakcontact Dubbel maakcontact	LED element, white Normally closed contact Double normally close contact Normally open contact Double normally open contact
1675	BT3xx Grundmodul	Module de base BT3xx	Modulo base BT3xx	BT3xx basismodule	BT3xx basic module
1676	Blindabdeckung X30-X34	Cache X30-X34	Copertura schermata X30-X34	Blinde afdekking X30-X34	X30-X34 blank cover
1680	Durchgangsklemme Orange 4-fach	Borne de passage Orange 4 cond.	Morsetto passante arancione quadruplo	Doorverbindingsklem oranje 4-voudig	Orange 4-conductor through terminal
1685	Durchgangsklemme PE 4-fach	Borne de passage PE 4 cond.	Morsetto passante PE quadruplo	Doorverbindingsklem PE 4-voudig	PE 4-conductor through terminal
1690	Durchgangsklemme Grau 4-fach	Borne de passage Gris 4 cond.	Morsetto passante grigio quadruplo	Doorverbindingsklem grijs 4-voudig	Grey 4-conductor through terminal
1695	Durchgangsklemme N 4-fach	Borne de passage N 4 cond.	Morsetto passante N quadruplo	Doorverbindingsklem N 4-voudig	N 4-conductor through terminal
1700	Kabelverschraubung CLICK	Passe-câble à vis CLIC	Passacavo a vite CLICK	Kabelwartel CLICK	CLICK cable gland
1701	CLICK Werkzeug	Outil CLIC	Attrezzo CLICK	CLICK-gereedschap	CLICK tool
1705	Durchgangsklemme Grau 2-fach	Borne de passage Gris 2 cond.	Morsetto passante grigio doppio	Doorverbindingsklem grijs 2-voudig	Grey 2-conductor through terminal
1710	Durchgangsklemme Orange 2-fach	Borne de passage Orange 2 cond.	Morsetto passante arancione doppio	Doorverbindingsklem oranje 2-voudig	Orange 2-conductor through terminal
1715	Sicherungsautomat	Coupe-circuit automatique	Interruttore automatico	Zekering	Circuit breaker
1716	Klemmleiste	Bornier	Morsettiera	Klemmenstrook	Terminal block
1735	Leuchtwahlflaste, 3 Stufig, rastend	Selecteur rétro-éclairé, 3 positions, verrouillable	Tasto di selezione illuminazione, a 3 stadi, stabile	Verlichte keuzeschakelaar, 3 standen, blokkerend	Illuminated selector button, 3-step, locking
1740	Leuchtwahlflaste, 3 Stufig	Selecteur rétro-éclairé, 3 positions	Tasto di selezione illuminazione, a 3 stadi	Verlichte keuzeschakelaar, 3 standen	Illuminated selector button, 3-step
1745	Leuchtwahlflaste, 2 Stufig	Selecteur rétro-éclairé, 2 positions	Tasto di selezione illuminazione, a 2 stadi	Verlichte keuzeschakelaar, 2 standen	Illuminated selector button, 2-step
1750	Dichtung	Joint	Guarnizione	Afdichting	Seal
1755	Handbedienidisplay «Thermowatt»	Écran de commande manuelle «Thermowatt»	Display a comando manuale "Thermowatt"	Handbedieningsdisplay "Thermowatt"	«Thermowatt» manual control display
1760	Leistungsregler RWF55	Régulateur de puissance RWF55	Regolatore di potenza RWF55	Vermogensregelaar RWF55	RWF55 power control



Pos.	Art. Nr.
1800	65 311 918
1805	65 311 940
1810	65 311 949
1811	65 311 950
1825	65 311 951
	65 311 952
	65 312 037
	65 311 953
1826	65 311 954
1830	65 311 955

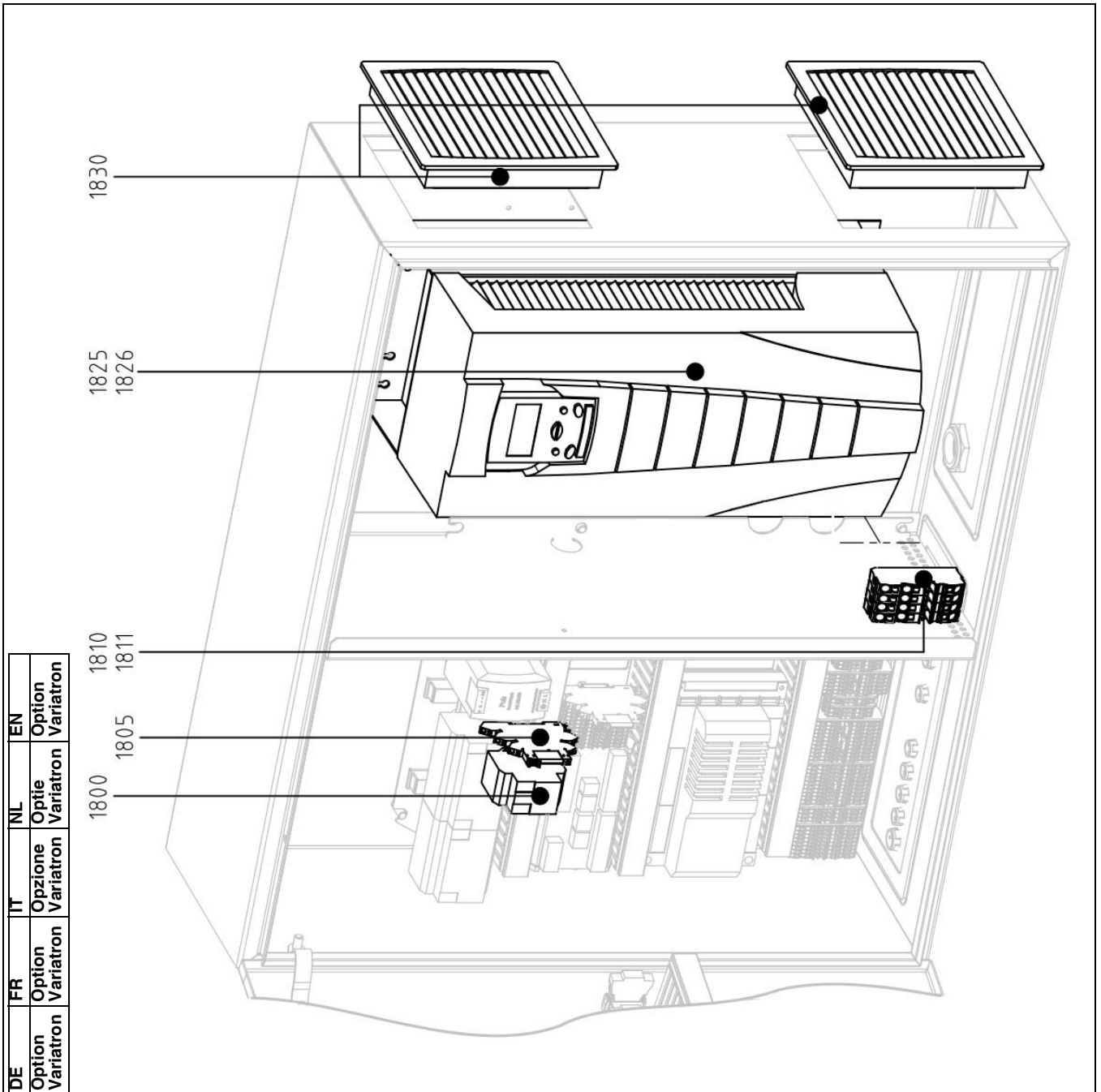

Pos.	Bezeichnung	Désignation	Descrizione	Naam	Description
1800	VSM100-Modul	Module VSM100	Modulo VSM100	VSM100-module	VSM100 module
1805	Relais	Relais	Relè	Relais	Relay
1810	Durchgangsklemme Grau	Borne de passage Gris	Morsetto passante grigio	Doorverbindingsklem grijs	Grey through terminal
1811	Durchgangsklemme PE	Borne de passage PE	Morsetto passante PE	Doorverbindingsklem PE	PE through terminal
1825	Frequenzumrichter	Convertisseur de fréquence	Convertitore di frequenza	Frequentieomvormer	Frequency inverter
1826	Hauptlüfter Frequenzumrichter	Ventilateur principal Convertisseur de fréquence	Ventilatore principale convertitore di frequenza	Hoofventilator frequentieomvormer	Main fan frequency inverter
1830	Filter	Filtre	Filtro	Filter	Filter



Pos.		Art. Nr.
1860	N6	65 311 794
	N7.3600	65 312 033
	N7.4500	65 311 776
1861	N6/N7	65 311 795
1865	N6/N7	65 311 948

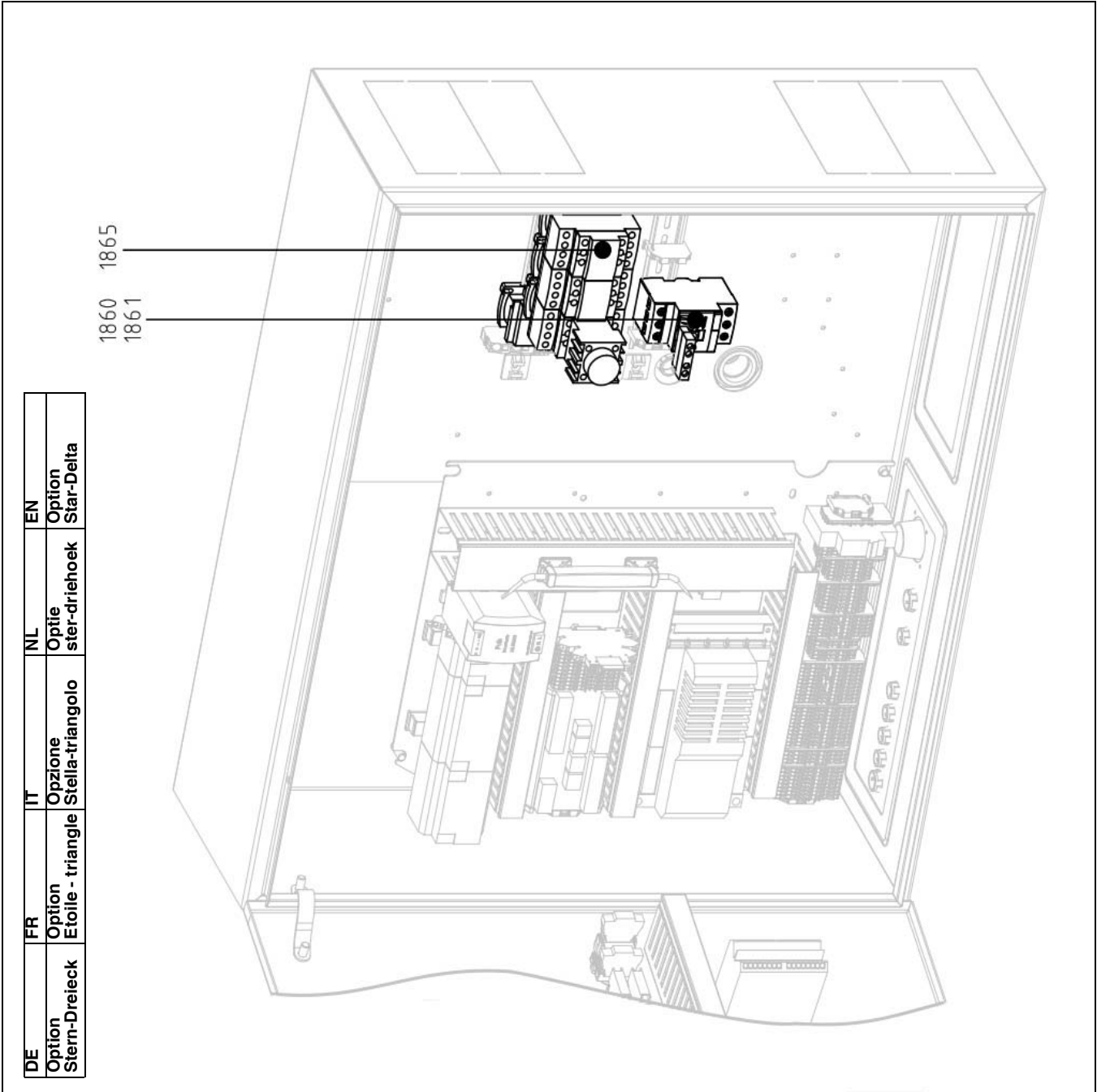

DE	FR	IT	NL	EN
Option Stern-Dreieck	Option Etoile - triangle	Opzione Stella-triangolo	Optie ster-driehoek	Option Star-Delta

Pos.	Bezeichnung	Designation	Descrizione	Naam	Description
1860	Motorschutzschalter Gebläse	Disjoncteur-protecteur de moteur du ventilateur	Interruttore di protezione motore ventilatore	Motorbeveiligingsschakelaar ventilator	Fan motor protection switch
1861	Hilfsschalter	Commutateur auxiliaire	Interruttore ausiliario	Hulpschakelaar	Auxiliary switch
1865	Motorstarter Gebläse	Démarrreur de moteur du ventilateur	Ventilatore avviamento motore	Motorstarter voor ventilator	Motor starter for fan



DE	FR	IT	NL	EN
Option Etamatic extern	Option Etamatic extern	Opzione Etamatic extern	Optie Etamatic extern	Option Etamatic extern

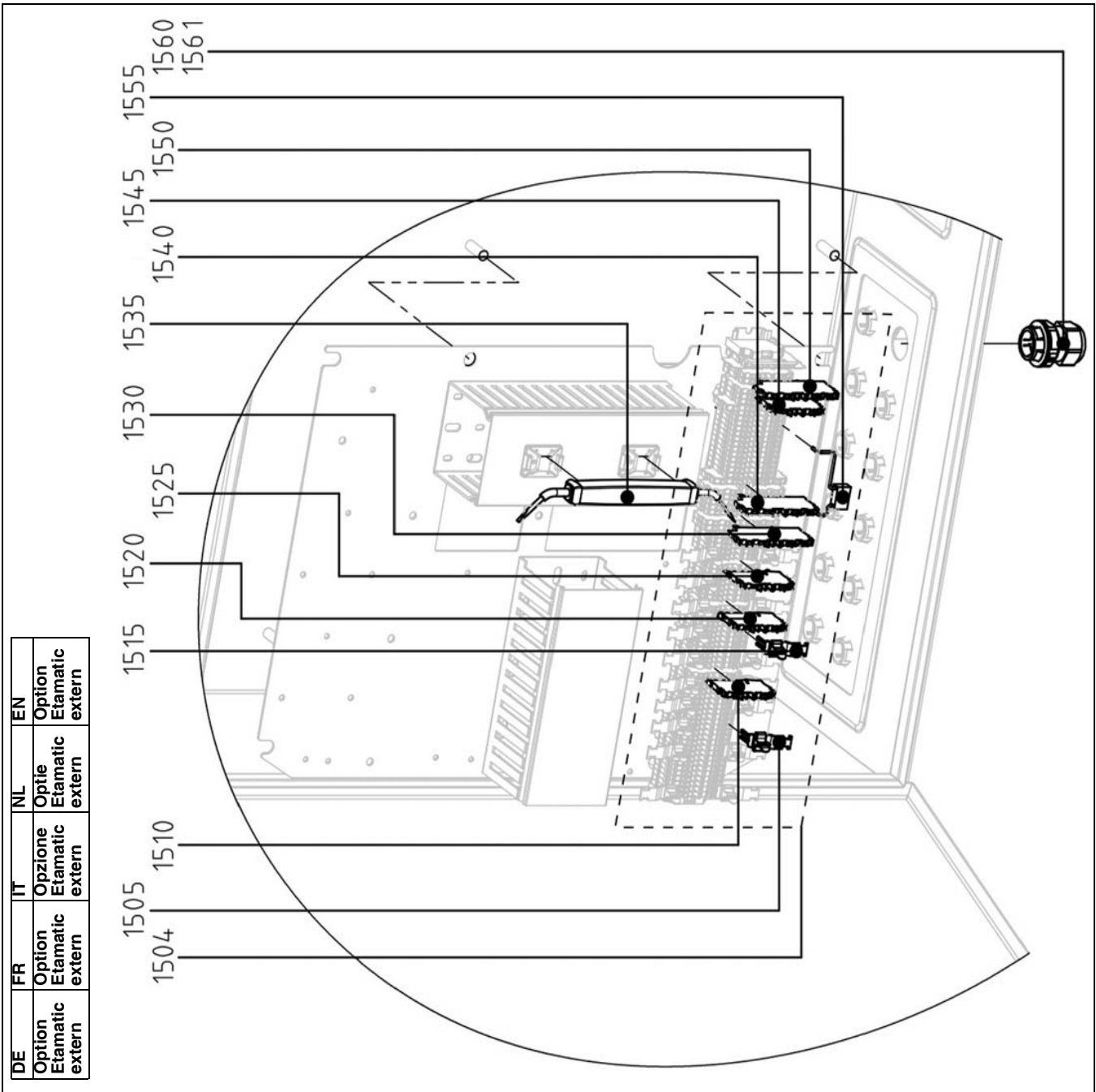

Pos.		Art. Nr.
1504	N6/N7	65 312 024
1505	N6/N7	65 311 440
1510	N6/N7	65 311 441
1515	N6/N7	65 311 442
1520	N6/N7	65 311 443
1525	N6/N7	65 311 444
1530	N6/N7	65 311 445
1535	N6/N7	65 311 446
1540	N6/N7	65 311 447
1545	N6/N7	65 311 448
1550	N6/N7	65 311 449
1555	N6/N7	65 311 450
1560	N6/N7 - CLICK M16 N6/N7 - CLICK M20 N6/N7 - CLICK M25	65 311 451 65 311 758 65 311 759
1561	N6/N7 - CLICK M16 N6/N7 - CLICK M20 N6/N7 - CLICK M25	65 311 786 65 311 787 65 311 788



Pos.	Bezeichnung	Designation	Descrizione	Naam	Description
1504	Klemmleiste	Bornier	Morsettiera	Klemmenstrook	Terminal block
1505	EMV Steckfuß 3-6 mm	Pied emboîtable CEM 3-6 mm	Pin connettore EMC 3-6 mm	EMV stekkervoet 3-6 mm	EMC terminal clamp 3-6 mm
1510	Durchgangsklemme orange 2-fach	Borne de passage orange, 2 cond.	Morsetto passante arancione doppio	Doorverbindingsklem orange 2-voudig	Orange 2-conductor through terminal
1515	EMV Steckfuß 6-8 mm	Pied emboîtable CEM 6-8 mm	Pin connettore EMC 6-8 mm	EMV stekkervoet 6-8 mm	EMC terminal clamp 6-8 mm
1520	Durchgangsklemme grau 2-fach	Borne de passage grise, 2 cond.	Morsetto passante grigio doppio	Doorverbindingsklem grijs 2-voudig	Grey 2-conductor through terminal
1525	Durchgangsklemme PE 2-fach	Borne de passage PE, 2 cond.	Morsetto passante PE doppio	Doorverbindingsklem PE 2-voudig	PE 2-conductor through terminal
1530	Durchgangsklemme PE 4-fach	Borne de passage PE, 4 cond.	Morsetto passante PE quadruplo	Doorverbindingsklem PE 4-voudig	PE 4-conductor through terminal
1535	Betätigungswerkzeug	Outil de manœuvre	Attrezzo di azionamento	Bedieningsgereedschap	Operating tool
1540	Durchgangsklemme N 4-fach	Borne de passage N, 4 cond.	Morsetto passante N quadruplo	Doorverbindingsklem N 4-voudig	N 4-conductor through terminal
1545	Durchgangsklemme N 2-fach	Borne de passage N, 2 cond.	Morsetto passante N doppio	Doorverbindingsklem N 2-voudig	N 2-conductor through terminal
1550	Durchgangsklemme grau 4-fach	Borne de passage grise, 4 cond.	Morsetto passante grigio quadruplo	Doorverbindingsklem grijs 4-voudig	Grey 4-conductor through terminal
1555	Prüflast ETAMATIC	Charge d'essai ETAMATIC	Carico di prova ETAMATIC	Testbelasting ETAMATIC	ETAMATIC test load
1560	Kabelverschraubung CLICK	Passe-câble a vis CLIC	Passacavo a vite CLICK	Kabelwartel CLICK	CLICK cable gland
1561	CLICK Werkzeug	Outil CLIC	Attrezzo CLICK	CLICK-gereedschap	CLICK tool



---

	<b>Legende</b>	<b>Légende</b>	<b>Legenda</b>	<b>Legend</b>	<b>Caption</b>
	<b>Hilfsmaterial</b>	<b>Pièces d'entretien</b>	<b>Materiali di consumo</b>	<b>Onderhoudsonderdelen</b>	<b>Maintenance parts</b>
	<b>Ersatzteile</b>	<b>Pièces de rechange</b>	<b>Parti ricambi</b>	<b>Reservedelsliste</b>	<b>Spare parts</b>
	<b>Verschleissteile</b>	<b>Pièces d'usure</b>	<b>Parti di usura</b>	<b>Slijtageonderdelen</b>	<b>Wearing parts</b>

Pos.	Art. Nr.
500	N6.2400/2900 KN
	N6.2400/2900 KM
	N6.2400/2900 KL
511	N7.3600/4500 KN
	N7.3600/4500 KM
	N7.3600/4500 KL
512	N6/7.2400/4500 KN/KL
513	N6/7.2400/4500 KN/KL
514	N6/7.2400/4500 KN/KL
515	N6/7.2400/4500 KN/KL
516	N6/7.2400/4500 KN/KL
517	N6/7.2400/4500 KN/KL
520	N6/7.2400/4500 KN/KL
530	N6.2400/2900 KN
	N6.2400/2900 KM
	N6.2400/2900 KL
550	N7.3600/4500 KN
	N7.3600/4500 KM
	N7.3600/4500 KL
550	N6/7.2400/4500 KN/KL

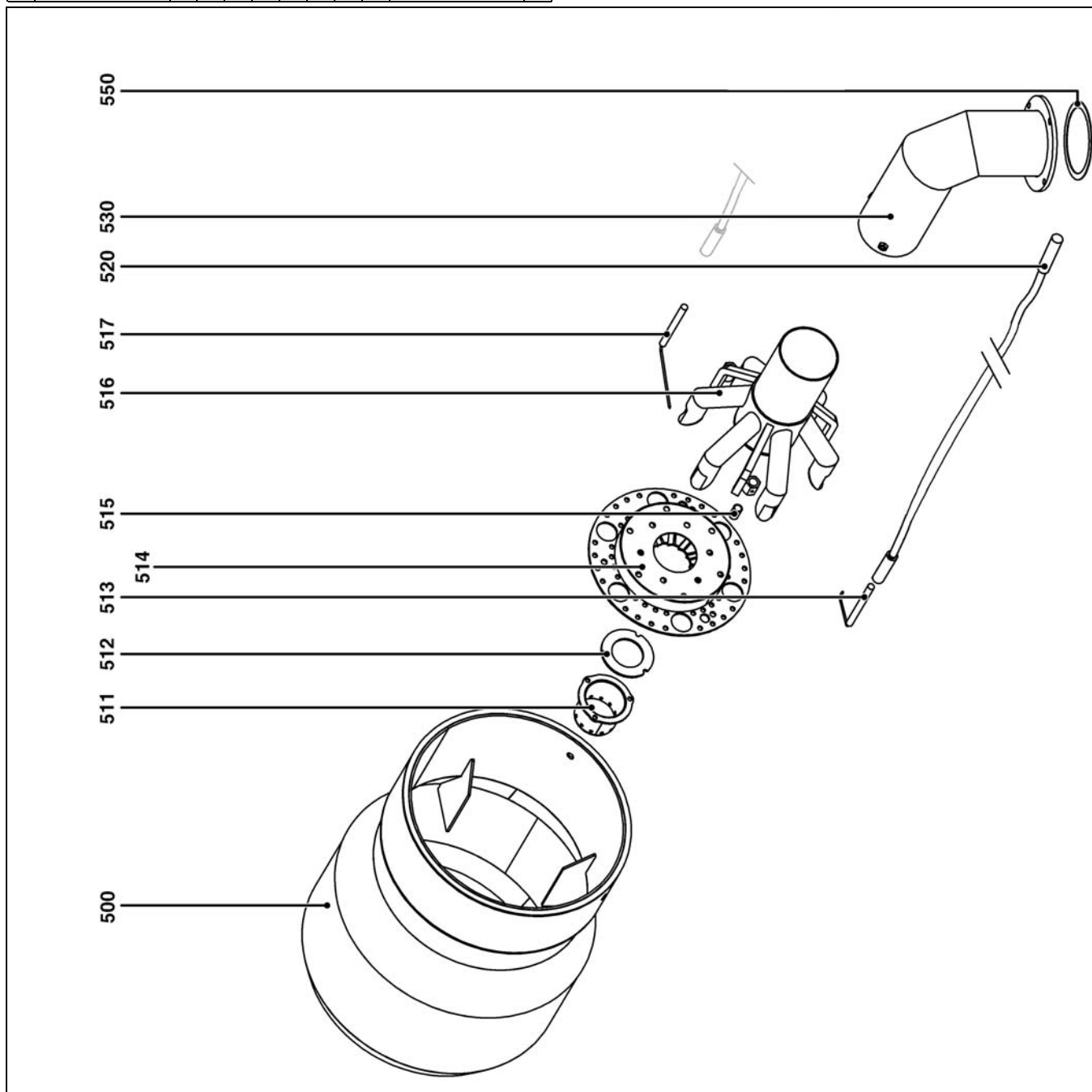

Pos.	Наименование	Denominación	Opis	Tanım	Designação
500	Сопло горелки	Тубо del quemador	Rura palnika	Brüör borusu	Tubo do queimador
511	Диффузор	Дифусор	Dysza gazu	Difüzör	Difusor
512	Уплотнение	Junta	Uszczelka	Conta	Junta
513	Запальный электрод	Electrodo de ignición	Elektroda zapłonowa	Ateşleme elektrodu	Eléctrodo do inflamador
514	Дефлектор	Deflector	Deflektor	Deflektör	Defletor
515	Прижимная втулка	Anillo de apriete	Pierścień zaciskowy	Sıkma halkası	Anel de aperto
516	Газовая разводка	Estrella para gas	Złącze gniazdowe do instalacji gazowej	Gaz yıldızı	Estrela gás
517	Датчик ионизации	Sonda de ionización	Sonda jonizacyjna	İyonlaşma sondası	Sonda ionização
520	Кабель розжига	Cable de encendido	Przewód zapłonowy	Ateşleme kablosu	Cabo do inflamador
530	Трубка подвода газа + газовое колено	Tubo de conducción de gas + codo	Przewód doprowadzania gazu+kolancko	Gaz geliş borusu + dirsek	Tubo de entrada de gás + cotovelo
550	Уплотнение	Junta	Uszczelka	Conta	Junta

Pos.		Art. Nr.
550	N6/7.2400/4500	65311 476
551	N6/7.2400/4500	65311 617
552	N6/7.2400/4500	65311 478
553	N6.2400/2900	65311 490
	N7.3600/4500	65311 474
556	N6/7.2400/4500	118 060 3227
557	N6/7.2400/4500	118 805 2260
558	N6/7.2400/4500	118 055 9591
559	N6/7.2400/4500	65311 471
560	N6/7.2400/4500	65311 472
561	N6/7.2400/4500	65311 595
563	N6/7.2400/4500	--
	BT3xx	
	Etamatic	65312 487
566	N6/7.2400/4500	65311 650
	BT3xx	
	Etamatic	65311 833
567	N6.2400	65311 824
	N6.2900	65311 825
	N7.3600	65311 353
	N6.4500	65311 826
568	N6/7.2400/4500	65311 502
570	N6/7.2400/4500	65311 477
573	N6/7.2400/4500	65311 512
576	N6.2400	65311 500
	N6.2900	65311 489
	N7.3600	65311 473
	N6.4500	65311 501
577	N6/7.2400/4500	65311 544
579	N6.2400/2900	65311 827
	N7.3600/4500	65311 828

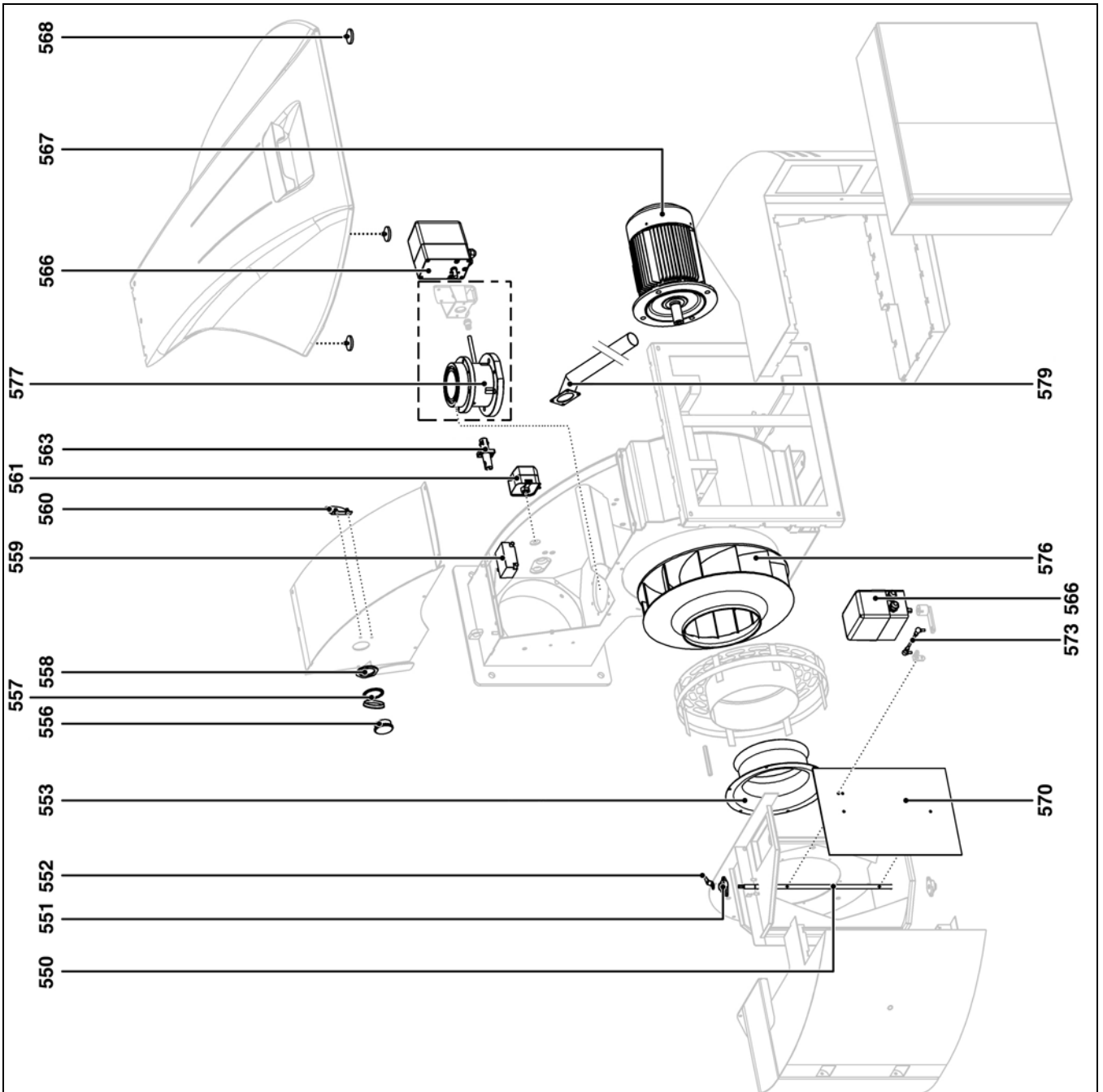

Pos.	Наименование	Denominación	Opis	Tanım	Designação
550	Ось заслонки	Eje de válvula	Oś przepustnicy	Klape aksi	Eixo borboleta
551	Подшипник	Palier	Podpórka	Yatak	Plataforma
552	Рычаг воздушной заслонки	Palanca de válvula de aire	Dźwignia przepustnicy powietrza	Hava klapesi kolu	Alavanca borboleta de ar
553	Рециркулятор	Reciclaje	Układ recyrkulacji	Dahili sirkülasyon	Entrada de ar
556	Сигнальная лампа	Testigo	Wzernik	Ikaz lambasi	Visor
557	Колпачок глаза	Tapa de testigo	Oslona wzernika	Ikaz lambasi muhafazasi	Tampa do visor
558	Гайка глаза	Tuerca de testigo	Nakrętka wzernika	Ikaz lambasi somunu	Porca visor
559	Устройство розжига	Encendedor	Aparat zapłonowy	Ateşleyici	Ignição
560	Зеркало глаза	Espejo del testigo	Szkiełko wzernika	Ikaz işığı aynası	Espelho do visor
561	Реле давления воздуха	Manostato de aire	Czujnik ciśnienia powietrza	Hava basınç şalteri	Manóstatto de ar
563	Контроль пламени	Vigilancia de llama	Kontrola płomienia	Alev gözetimi	Vigilância de chama
566	Серводвигатель систем подачи воздуха и газа	Servomotor de aire y de gas	Servomotor przepustnicy powietrza i gazu	Hava ve gaz servo motoru	Servomotor ar e gás
567	Электродвигатель	Motor	Silnik	Motor	Motor
568	Магнит фиксации кожуха	Imán de fijación de la tapa	Magnes mocowania pokrywy	Muhafaza kapağı bağlantı mknatısı	Elemento fixação cobertura
570	Воздушная заслонка	Válvula de aire	Przepustnica powietrza	Hava klapesi	Borboleta de ar
573	Тяга воздушной заслонки	Bieleta de válvula de aire	Trzpień przepustnicy powietrza	Hava klapesi kolu	Biela borboleta de ar
576	Рабочее колесо	Turbina	Turbina	Türbin	Turbina
577	Газовый клапан в сборе	Válvula de mariposa de gas montada	Zmontowany zawór gazu	Gaz klapesi grubu	Conjunto válvula de gás
579	Соединительная Деталь для охлаждения FU	Tubo de refrigeración para el convertidor de frecuencias	Łącznik chłodzenia FU	Soğutma FU için bağlantı parçası	Tubo de arrefecimento do variador

Pos.		Art. Nr.
3010	N6/7.2400/4500-Rp1½"	65311 503
	N6/7.2400/4500-Rp2"	65311 488
3020	N6/7.2400/4500	65311 606
3030	N6/7.2400/4500	65311 604
3040	N6/7.2400/4500	65311 579
3060	N6/7.2400/4500-Rp1½"	65311 580
	N6/7.2400/4500-Rp2"	65311 581
3070	N6/7.2400/4500	65107 100
3080	N6/7.2400/4500	65311 585
3090	N6/7.2400/4500	147 883 6180
3110	N6/7.2400/4500-Rp1½"	65313 107
	N6/7.2400/4500-Rp2"	65311 377
3120	N6/7.2400/4500	
	GW500 A5 (30-500 mbar)	13010 091
	GW150 A6 (Option)	65311 597
3130	N6/7.2400/4500	65311 586
3140	N6/7.2400/4500	65311 615
3300	Rp1½"	65311 458
	Rp2"	65311 459
	DN65	65311 460
	DN80	65311 461
3301	Rp1½"	65311 361
	DN65	65311 723
	DN80	65311 888
5010	N6/7.2400/4500	65311 362

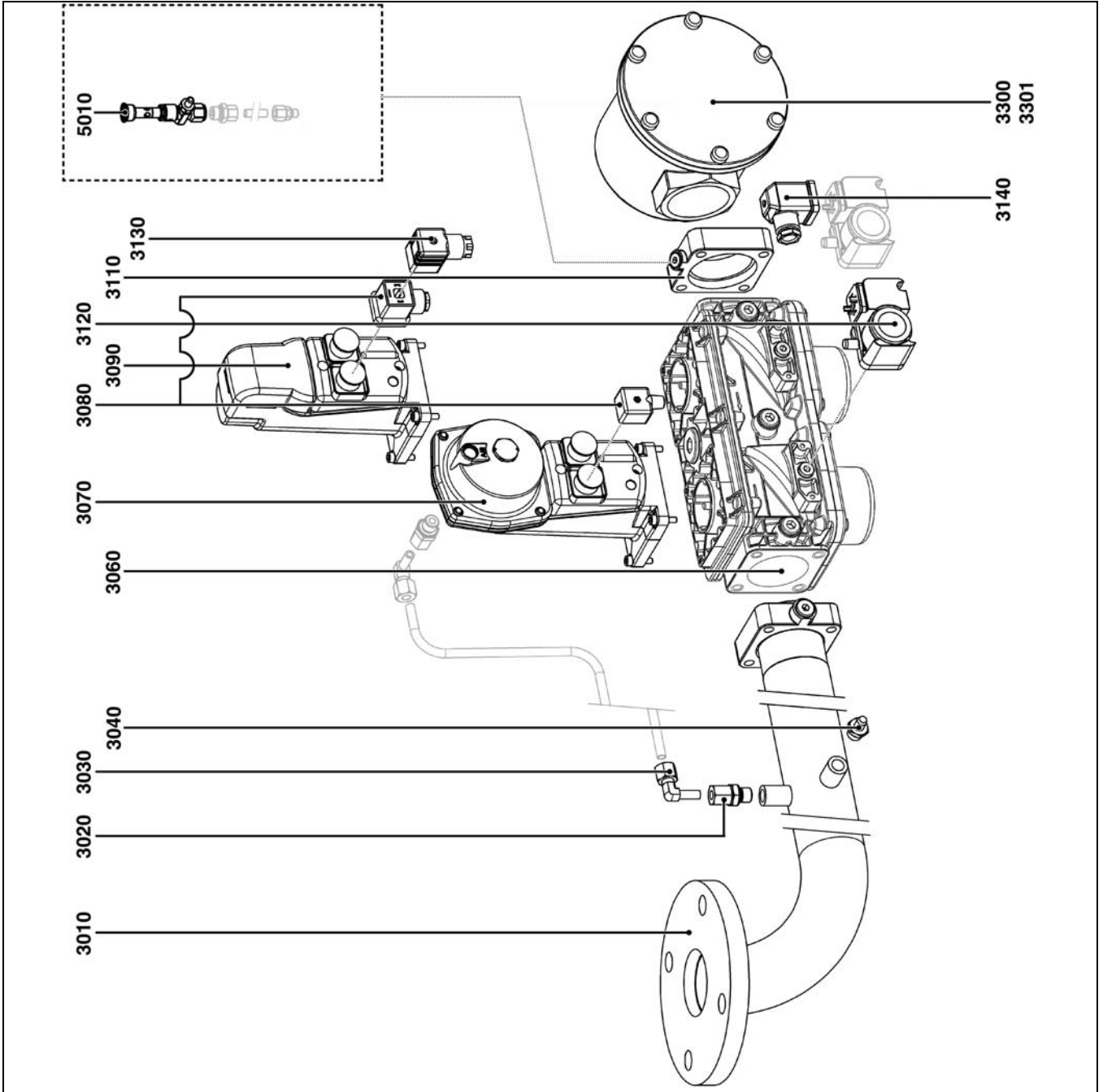

Pos.	Наименование	Denominación	Opis	Tanım	Designação
3010	Газовый коллектор	Colector de gas	Zbiornik gazowy	Gaz manifoldu	Coletor gás
3020	Прямой штуцер	Racor recto	Złącze prawe	Sağ rakor	Junta reta
3030	Поворотный угловой штуцер	Racor acodado orientable	Złączka typu kolanko do zmiany kierunku przepływu	Yönlendirilebilir dirsekli rakor	Cotovelo orientável
3040	Датчик давления + прокладка	Toma de presión + junta	Gniazdo pomiaru ciśnienia + uszczelka	Basinç girişi + conta	Tomada de pressão + junta
3060	Газовый клапан VGD	Válvula de gas VGD	Zawór gazowy VGD	VGD gaz vanası	Válvula gás VGD
3070	Регулятор SKP 25	Regulador SKP 25	Regulator SKP 25	SKP 25 regülatör	Regulador SKP 25
3080	Разъем клапанов	Toma de válvulas	Gniazdo zaworów	Vana girişi	Tomada válvulas
3090	Регулятор SKP 15	Regulador SKP 15	Regulator SKP 15	SKP 15 regülatör	Regulador SKP 15
3110	Соединительный фланец	Brida de conexión	Kolnierz do podłączenia	Bağlantı flanşı	Flange de ligação
3120	Реле давления газа	Manostato de gas	Czujnik ciśnienia gazu	Gaz basınç şalteri	Manóstato gás
3130	Разъем клапанов	Toma de válvulas	Gniazdo zaworów	Vana girişi	Tomada válvulas
3140	Разъем реле давления	Toma de manostato	Gniazdo czujnika ciśnienia	Basinç şalteri girişi	Tomada manóstato
3300	Фильтр	Filtro	Filtr	Filtre	Filtro
	Комплект запчастей для газового фильтра	Piezas de repuesto para filtro de gas	Kpl. części zamiennych do filtra gazu	Gaz filtresi için yedek parça seti	Kit cartucho filtrante
	Контрольная горелка с кнопочным крапом	Queimador de prueba con grifo de botón de presión	Palnik kontrolny z zaworem przyciskowym	Düğmeli musluklu test brülörü	Queimador de cabeça com botão torneira

Pos.	Art. Nr.
3510	Rp1"1/2 Rp2"
3580	Rp1"1/2 Rp2"
3620	Rp1"1/4 Rp1"1/2 Rp2"
3640	N6/7.2400/4500 GW500 A5 (30-500 mbar) GW150 A5 (Option)
3650	N6/7.2400/4500
3700	MBC 300 MBC 700 MBC 1200
3800	Rp1 1/2" Rp2" DN65 DN80
3801	Rp1 1/2" DN65 DN80
5010	N6/7.2400/4500

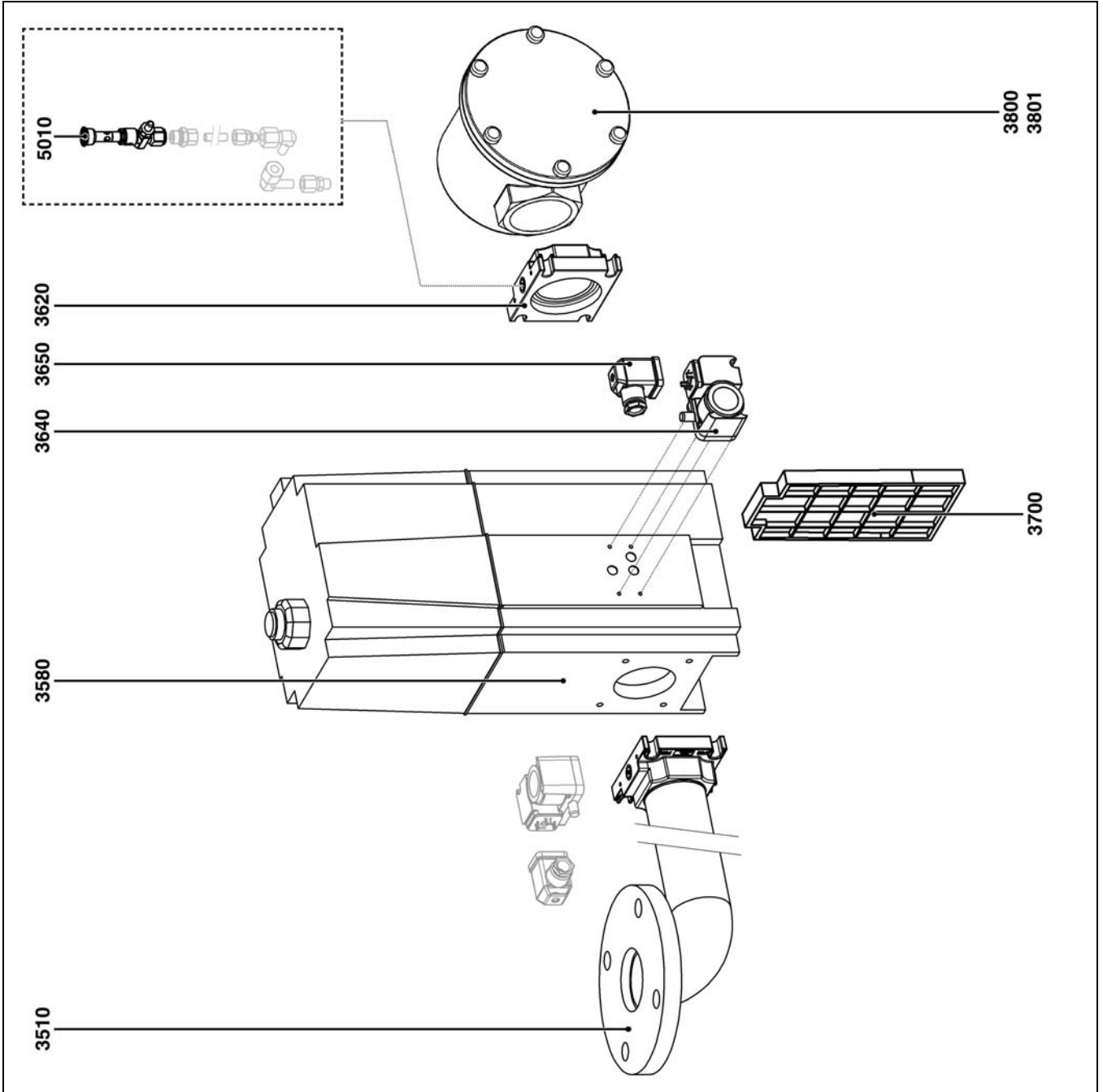

Pos.	Наименование	Denominación	Opis	Tanım	Designação
3510	Коллектор	Colector	Kolektor	Manifold	Coletor
3580	Клапан	Válvula	Zawór	Vana	Válvula
3620	Фланец	Brida	Kolnierz	Flanş	Flange
3640	Реле давления	Manostato	Czujnik ciśnienia	Basiñ şalteri	Manóstato
3650	Разъем реле давления	Toma de manostato	Gniazdo czujnika ciśnienia	Basiñ şalteri girişı	Tomada manóstato
3700	Фильтр / Клапан	Filtro / válvula	Filtr / zawór	Filtre / vana	Filtro/vão
3800	Фильтр	Filtro	Filtr	Filtre	Filtro
3801	Комплект запчастей для газового фильтра	Piezas de repuesto para filtro de gas	Kpl. części zamiennych do filtra gazu	Gaz filtresi için yedek parça seti	Kit cartucho filtrante
5010	Контрольная горелка с кнопочным краном	Queimador de prueba con grifo de botón de presión	Palnik kontrolny z zaworem przyciskowym	Düğmei musluklu test brülörü	Queimador de cabeça com botão torneira

Pos.		Art. Nr.
4010	DN65 DN80 DN100 DN125	65311 506 65311 494 65311 508 65311 509
4020	N6/7.2400/4500	65311 601
4030	N6/7.2400/4500	65311 605
4040	N6/7.2400/4500	65311 603
4060	N6/7.2400/4500	65311 607
4080	DN65 DN80 DN100 DN125	65323 661 65311 583 65311 590 65311 543
4090	N6/7.2400/4500	65107 100
4100	N6/7.2400/4500	65311 585
4110	N6/7.2400/4500	147 883 6180
4120	DN65 DN80 DN100 DN125 DN150	65311 611 65311 612 65311 613 65311 614 65311 342
4130	N6/7.2400/4500	65311 586
4140	N6/7.2400/4500	65311 615
4150	N6/7.2400/4500 GW500 A5 (30-500 mbar) GW150 A6 (Option)	13010091 65311 597
4300	DN65 DN80 DN100 DN125 DN150	65311 460 65311 461 65311 462 65311 463 65311 892
4301	DN65 DN80 DN100 DN125 DN150	65311 723 65311 888 65311 889 65311 890 65311 623
5010	N8/9.5700/6500	65311 362

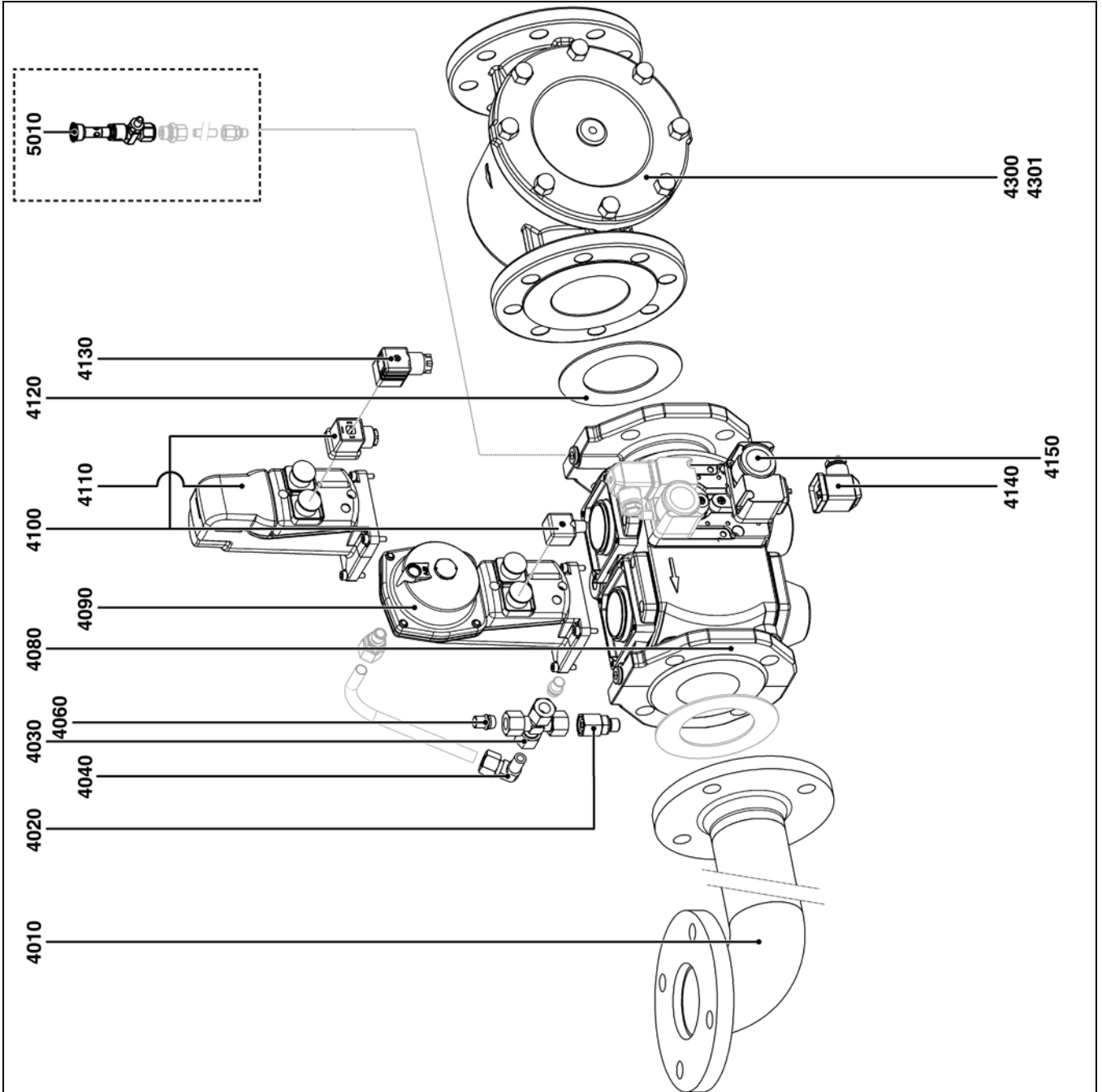

Pos.	Наименование	Denominación	Opis	Tanim	Designação
4010	Газовый коллектор	Colector de gas	Zbiornik gazowy	Gaz manifoldu	Coletor gás
4020	Прямой штуцер	Racor recto	Złącze prawe	Sağ rakor	Junta reta
4030	Штуцер	Racor	Złącze	Bağlantı	Junta
4040	Поворотный угловой штуцер	Racor acodado orientable	Złącza typu kolanko do zmiany kierunku przepływu	Yönlendirilebilir dirsekli rakor	Cotovelo orientável
4060	Пробка	Tapón	Zatyczka	Tapa	Bujão
4080	Газовый клапан VGD	Válvula de gas VGD	Zawór gazowy VGD	VGD gaz vanası	Válvula gás VGD
4090	Регулятор SKP25	Regulador SKP25	Regulator SKP25	SKP25 regülatörü	Regulador SKP 25
4100	Разъем клапан	Toma de válvula	Gniazdo zawór	Vanası girişi	Tomada válvulas
4110	Регулятор SKP15	Regulador SKP15	Regulator SKP15	SKP15 regülatörü	Regulador SKP 15
4120	Уплотнение	Junta	Uszczelka	Conta	Junta
4130	Штекерная розетка, клапанный привод	Conector regulador	Puszka przewodu napędu zaworu	Valf tahriki hat kutusu	Tomada regulador
4140	Разъем реле давления	Toma de manostato	Gniazdo czujnika ciśnienia	Basınç şalteri girişi	Tomada manóstato
4150	Реле давления газа	Manostato de gas	Czujnik ciśnienia gazu	Gaz basınç şalteri	Manóstato gás
4300	Фильтр	Filtro	Filtr	Filtre	Filtro
4301	Комплект запчастей для газового фильтра	Piezas de repuesto para filtro de gas	Kpl. części zamiennych do filtra gazu	Gaz filtresi için yedek parça seti	Kit cartucho filtrante
5010	Контрольная горелка с кнопочным краном	Queimador de prueba con grifo de botón de presión	Palnik kontrolny z zaworem przyciskowym	Düğmeli musluklu test brülörü	Queimador de cabeça com botão torneira

Pos.		Art. Nr.
4510	DN65 DN80 DN100	65311 506 65311 494 65311 508
4520	N6/7.2400/4500	65311 601
4530	N6/7.2400/4500	65311 344
4560		65311 607
4580	DN65 DN80 DN100	65311 844 65311 845 65311 846
4620	DN65 DN80 DN100 DN125 DN150	65311 611 65311 612 65311 613 65311 614 65311 342
4640	N6/7.2400/4500 GW500 A5 (30-500 mbar) GW150 A6 (Option)	13010091 65311 597
4650	N6/7.2400/4500	65311 615
4800	DN65 DN80 DN100 DN125 DN150	65311 460 65311 461 65311 462 65311 463 65311 892
4801	DN65 DN80 DN100 DN125 DN150	65311 723 65311 888 65311 889 65311 890 65311 623
5010	N6/7.2400/4500	65311 362

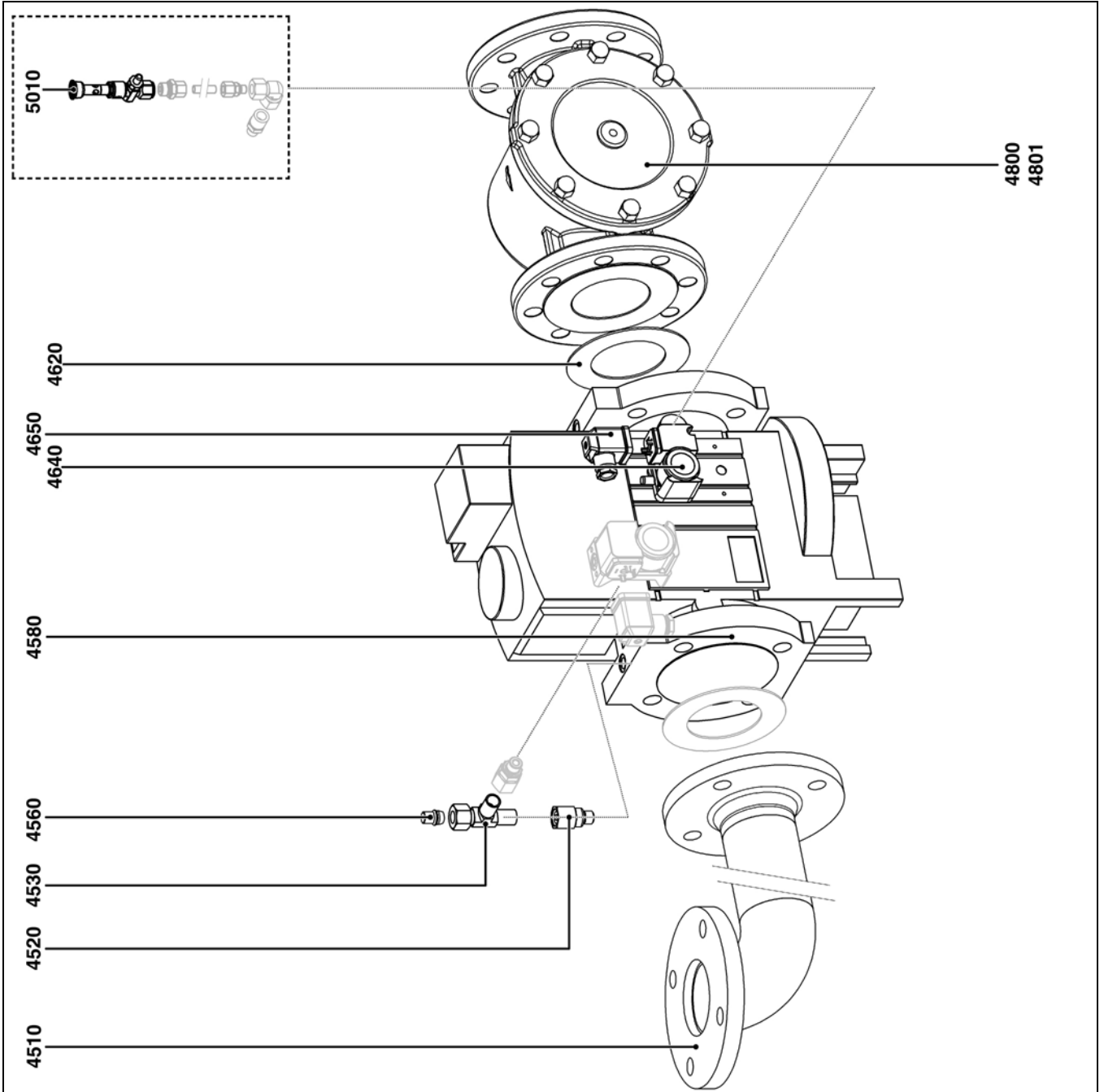

Pos.	Наименование	Denominación	Opis	Tanım	Designação
4510	Коллектор	Colector	Kolektor	Manifold	Coletor
4520	Прямой штуцер	Racor recto	Złącze prowe	Sağ rakor	Junta reta
4530	Поворотный штуцер	Racor orientable	Złącza do zmiany kierunku przepływu	Yönlendirilebilir dirsekli rakor	Junto orientável
4560	Пробка	Tapón	Zatyczka	Тapa	Bujão
4580	Клапан	Válvula	Zawór	Vana	Válvula
4620	Уплотнение	Junta	Uszczelka	Conta	Junta
4640	Реле давления	Manostato	Czujnik ciśnienia	Basınç şalteri	Manóstato
4650	Разъем реле давления	Toma de manostato	Gniazdo czujnika ciśnienia	Basınç şalteri girişi	Tomada manóstato
4800	Фильтр	Filtro	Filtr	Filtre	Filtro
4801	Комплект запчастей для газового фильтра	Piezas de repuesto para filtro de gas	Kpl. części zamiennych do filtra gazu	Gaz filtresi için yedek parça seti	Kit cartucho filtrante
5010	Контрольная горелка с кнопочным краном	Queimador de prueba con grifo de botón de presión	Palnik kontrolny z zaworem przyciskowym	Düğmeli musluklu test brülörü	Queimador de cabeça com botão torneira

RU	ES	PL	TR	PT
*	Оpción	Opcja	Opsiyon	Opcional

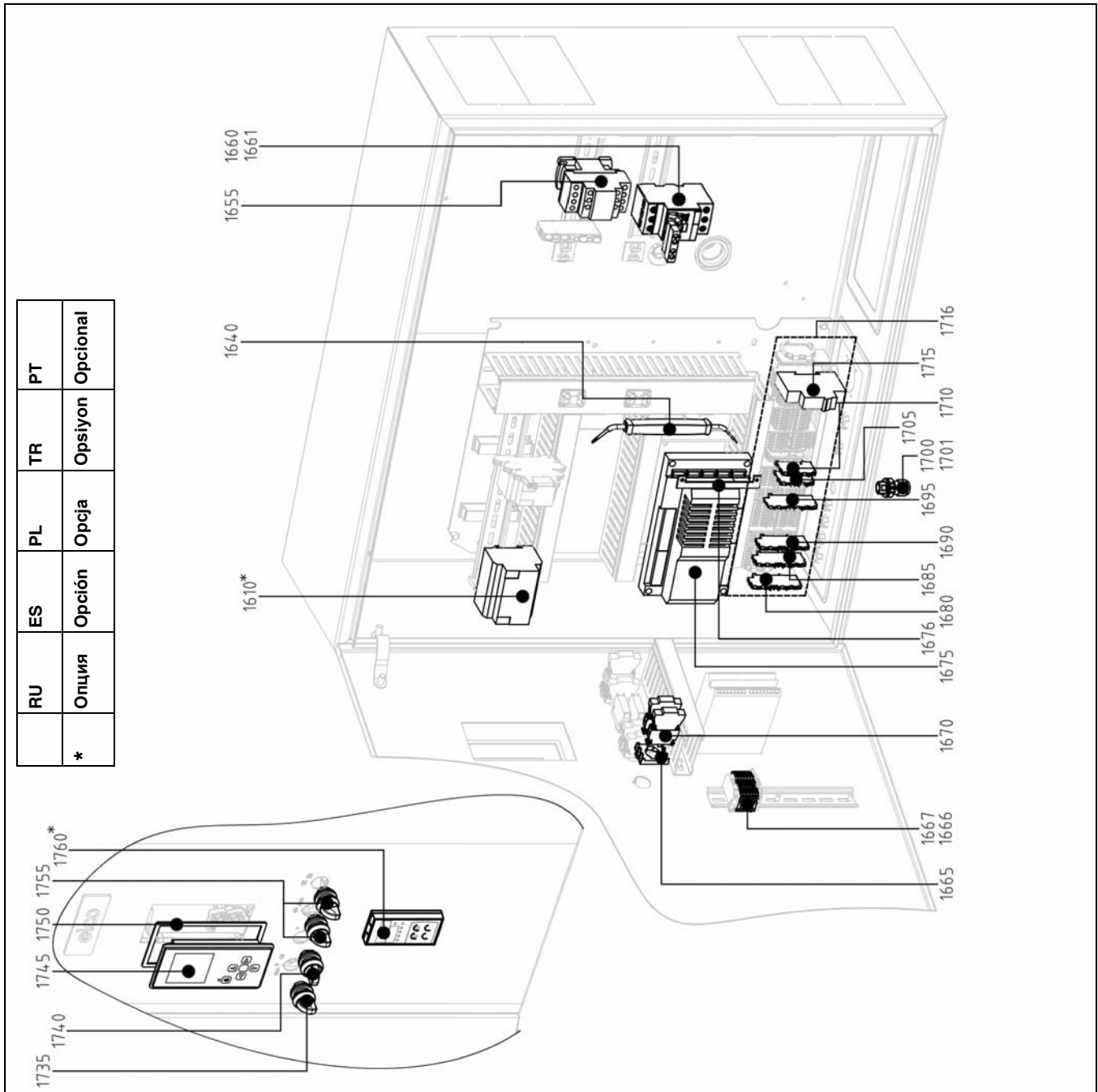

Pos.		Art. Nr.
1610*	N6/N7	65 311 790
1640	N6/N7	65 311 446
1655	N6	65 311 793
	N7.3600	65 312 032
	N7.4500	65 311 947
1660	N6	65 311 794
	N7.3600	65 312 033
	N7.4500	65 311 776
1661	N6/N7	65 311 795
1665	N6/N7	65 311 919
1666	N6/N7	65 311 443
1667	N6/N7	65 311 444
1670	N6/N7 - CLED230	65 311 920
	N6/N7 - CK01	65 311 921
	N6/N7 - CK02	65 311 922
	N6/N7 - CK10	65 311 923
	N6/N7 - CK20	65 311 924
1675	N6/N7 - BT 320	65 312 451
	N6/N7 - BT 330*	65 312 446
1676	N6/N7 - BT 3xx	65 311 926
1680	N6/N7	65 311 927
1685	N6/N7	65 311 445
1690	N6/N7	65 311 449
1695	N6/N7	65 311 447
1700	N6/N7 - CLICK M16	65 311 451
	N6/N7 - CLICK M20	65 311 758
	N6/N7 - CLICK M25	65 311 759
1701	N6/N7 - CLICK M16	65 311 786
	N6/N7 - CLICK M20	65 311 787
	N6/N7 - CLICK M25	65 311 788
1705	N6/N7	65 311 443
1710	N6/N7	65 311 441
1715	N6/N7 - 10A	65 311 931
1716	N6/N7	65 311 932
1735	N6/N7	65 311 436
1740	N6/N7	65 311 437
1745	N6/N7	65 326 869
1750	N6/N7	65 311 364
1755	N6/N7	65 311 438
1760*	N6/N7	65 114 033



Pos.	Назначение	Denominación	Opis	Tanim	Designação
1610	Модуль LCM100	Módulo LCM100	Modul LCM100	LCM100 modülü	Módulo LCM100
1636*	Блок питания	Bloque de alimentación	Zasilacz	Güç kaynağı	Transformador
1640	Инструменты	Herramienta de accionamiento	Narzędzie do przełączania	İşletim aracı	Ferramenta de manobra
1655	Вентилятор двигателя	Motor del ventilador	Silnik dmuchawy	Fan motoru	Motor ventilador
1660	Защитный выключатель двигателя вентилятора	Interruptor de protección del motor del ventilador	Wyłącznik ochronny silnika dmuchawy	Fan motor koruma şalteri	Disjuntor-protector de motor ventilador
1661	Главный контроллер	Interruptor auxiliar	Łącznik pomocniczy	Yardımcı şalter	Comutador auxiliar
1665	Шасси; 3 детали	Soporte para aparato, 3 niveles	Wspornik urządzenia, potrójny	Ekipman raflı, 3 gözlü	Porta-ferramentas triplo
1666	Прокладная клемма серая	Borne de paso gris	Zacisk przelotowy szary	Gri devre terminali	Borne de passagem cinzento
1667	Прокладная клемма PE	Borne de paso PE	Zacisk przelotowy PE	PE devre terminali	Borne de passagem PE
1670	"Светодиодный элемент, белый Размыкающий контакт Размыкающий двойной контакт Замыкающий контакт Замыкающий двойной контакт"	"Elemento LED, blanco Contacto de apertura Contacto de apertura doble Contacto de cierre Contacto de cierre doble"	"Element LED, biały Styki rozwiernie Podwójne styki rozwiernie Styki zwarte Podwójne styki zwarte"	"LED eleman, beyaz Kilit açma kontağı Cift kilit açma kontağı Kilit kapatma kontağı Cift kilit kapatma kontağı"	Elemento LED, branco Contacto de abertura Contacto de dupla abertura Contacto de fecho Contacto de duplo fecho
1675	Базовый модуль BT3xx	Módulo básico BT3xx	Modul podstawowy BT3xx	BT3xx ana modül	Módulo de base BT3xx
1676	Заглушка X30-X34	Cubierta X30-X34	Zaslepka X30-X34	Kör kapak X30-X34	Tampa X30 - X34
1680	Прокладная клемма оранжевая 4-кратная	Borne de paso naranja cuadruple	Zacisk przelotowy pomarańczowy poczwórny	Devre terminali, turuncu 4 gözlü	Borne de passagem Laranja 4 cond.
1685	Прокладная клемма PE 4-кратная	Borne de paso PE cuadruple	Zacisk przelotowy PE poczwórny	Devre terminali, PE 4 gözlü	Borne de passagem PE 4 cond.
1690	Прокладная клемма серая 4-кратная	Borne de paso gris cuadruple	Zacisk przelotowy szary poczwórny	Devre terminali, gri 4 gözlü	Borne de passagem Cinzento 4 cond.
1695	Прокладная клемма N 4-кратная	Borne de paso N cuadruple	Zacisk przelotowy N poczwórny	Devre terminali, N 4 gözlü	Borne de passagem N 4 cond.
1700	Кабельный соединитель CLICK	Racor atornillado para cables CLICK	Połączenie gwintowane okablowania CLICK	Kablo rakoru CLICK	Passa-cabos com parafuso CLIC
1701	Инструмент CLICK	Herramienta CLICK	Narzędzie CLICK	CLICK aracı	Ferramenta CLIC
1705	Прокладная клемма серая 2-кратная	Borne de paso gris doble	Zacisk przelotowy szary podwójny	Devre terminali, gri 2 gözlü	Borne de passagem Cinzento 2 cond.
1710	Прокладная клемма оранжевая 2-кратная	Borne de paso naranja doble	Zacisk przelotowy pomarańczowy podwójny	Devre terminali, turuncu 2 gözlü	Borne de passagem Laranja 2 cond.
1715	Автоматический выключатель	Fusible automático	Bezpiecznik automatyczny	Emniyet otomatığı	Corta-circuitos automático
1716	Клеммная колодка	Regleta de bornes	Listwa zaciskowa	Terminal bloğu	Bloco terminal
1735	Светящаяся кнопка, 3-поз., с фиксацией	Botón de selección luminoso, 3 niveles, encajable	Podświetlany przycisk wyboru, 3-stopniowy, bistabilny	İşikli seçim tuşu, 3 kademeli, dlişli	Seletor retro-iluminado, 3 posições, bloqueável
1740	Кнопка с подсветкой, 3-ступенчатая	Botón de selección luminoso, 3 niveles	Podświetlany przycisk wyboru, 3-stopniowy	İşikli seçim tuşu, 3 kademeli	Seletor retro-iluminado, 3 posições
1745	Кнопка с подсветкой, 2-ступенчатая	Botón de selección luminoso, 2 niveles	Podświetlany przycisk wyboru, 2-stopniowy	İşikli seçim tuşu, 2 kademeli	Seletor retro-iluminado, 2 posições
1750	Уплотнительная прокладка	Junta	Uszczelka	Conta	Junta
1745	Дисплей ручного управления «Thermowatt»	Pantalla de manejo manual, «Thermowatt»	Wyświetlacz do obsługi ręcznej „Thermowatt”	«Thermowatt» el kumandası ekranı	Ecrã de comando manual "Thermowatt"
1760	Регулятор мощности RWF40	Regulador de potencia RWF40	Regulator mocy RWF40	RWF40 güç regülatörü	Regulador de potencia RWF40

Pos.		Art. Nr.
1800	N6/N7	65 311 918
1805	N6/N7	65 311 940
1810	N6/N7	65 311 949
1811	N6/N7	65 311 950
1825	N6.2400	65 311 951
	N6.2900	65 311 952
	N7.3600	65 312 037
	N7.4500	65 311 953
1826	N6/N7	65 311 954
1830	N6/N7	65 311 955

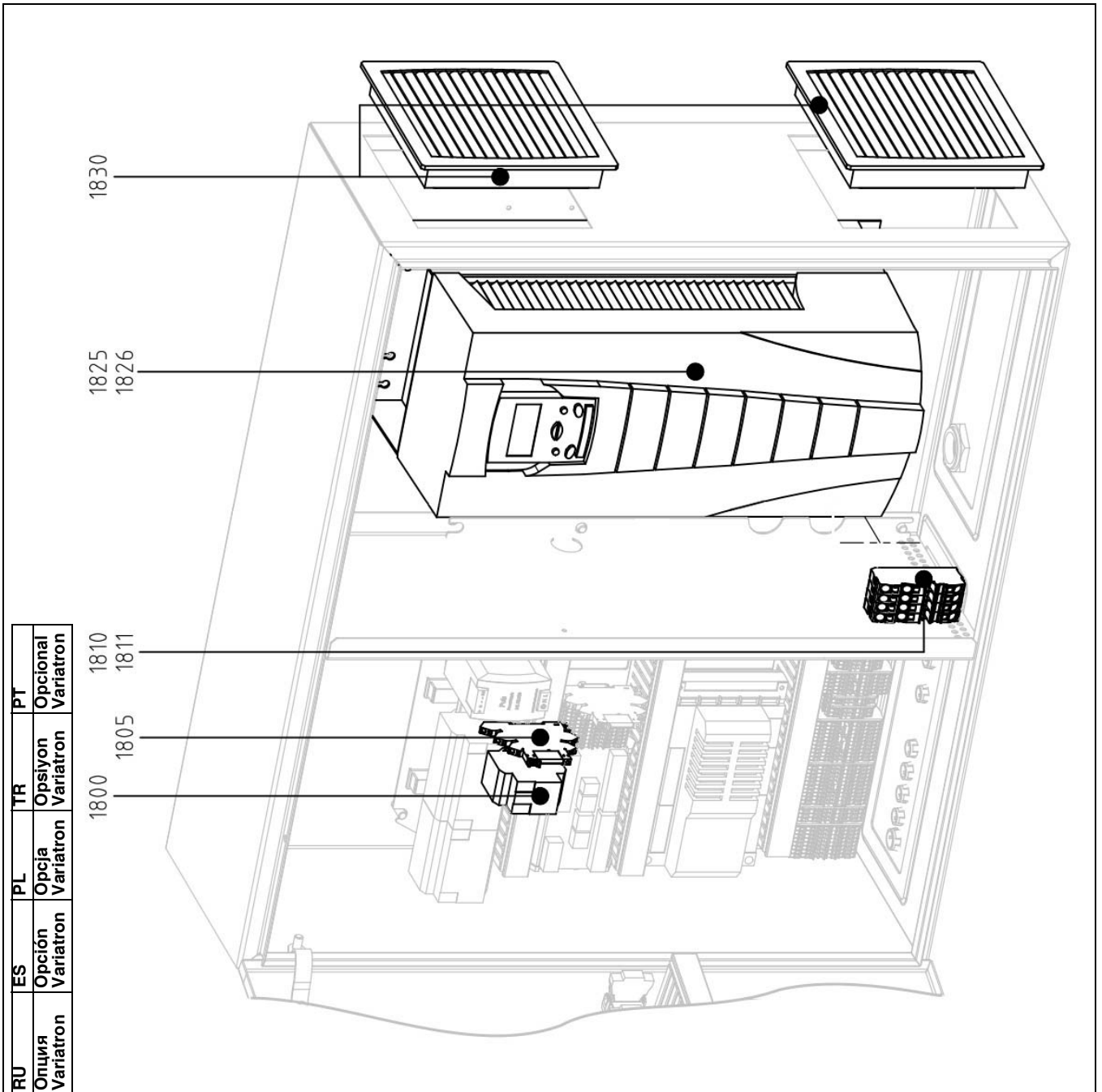

RU	ES	PL	TR	PT
Опция	Оpción	Opcja	Opsiyon	Opcional
Variatron	Variatron	Variatron	Variatron	Variatron

Pos.	Назначение	Denominación	Opis	Tanım	Designação
1800	Модуль VSM100	Мódulo VSM100	Modul VSM100	VSM100 modülü	Módulo VSM100
1805	Реле	Relé	Przełącznik	Röle	Relé
1810	Проходная клемма серая	Borne de paso gris	Zacisk przelotowy szary	Gri devre terminali	Borne de passagem cinzento
1811	Проходная клемма PE	Borne de paso PE	Zacisk przelotowy PE	PE devre terminali	Borne de passagem PE
1825	преобразователь частоты	Convertidor de frecuencias	Przetwornica częstotliwości	Frekans dönüştürücü	Conversor de frequência
1826	Вентилятор главного проветривания, преобразователь частоты	Ventilador principal del convertidor de frecuencias	Przetwornica częstotliwości wentylatora głównego	Frekans dönüştürücü için ana fan	Ventilador principal Conversor de frequência
1830	Фильтр	Filtro	Filtr	Filtre	Filtro

Pos.	Art. Nr.
1860	N6 65 311 794
	N7.3600 65 312 033
	N7.4500 65 311 776
1861	N6/N7 65 311 795
1865	N6/N7 65 311 948

RU	ES	PL	TR	PT
Опция звезда-треугольник	Opção estrela-triângulo	Opcja gwiazda-trójkąt	Opسیون یıldیز üçgen	Opção Estrela - triângulo

1860 1865  
1861

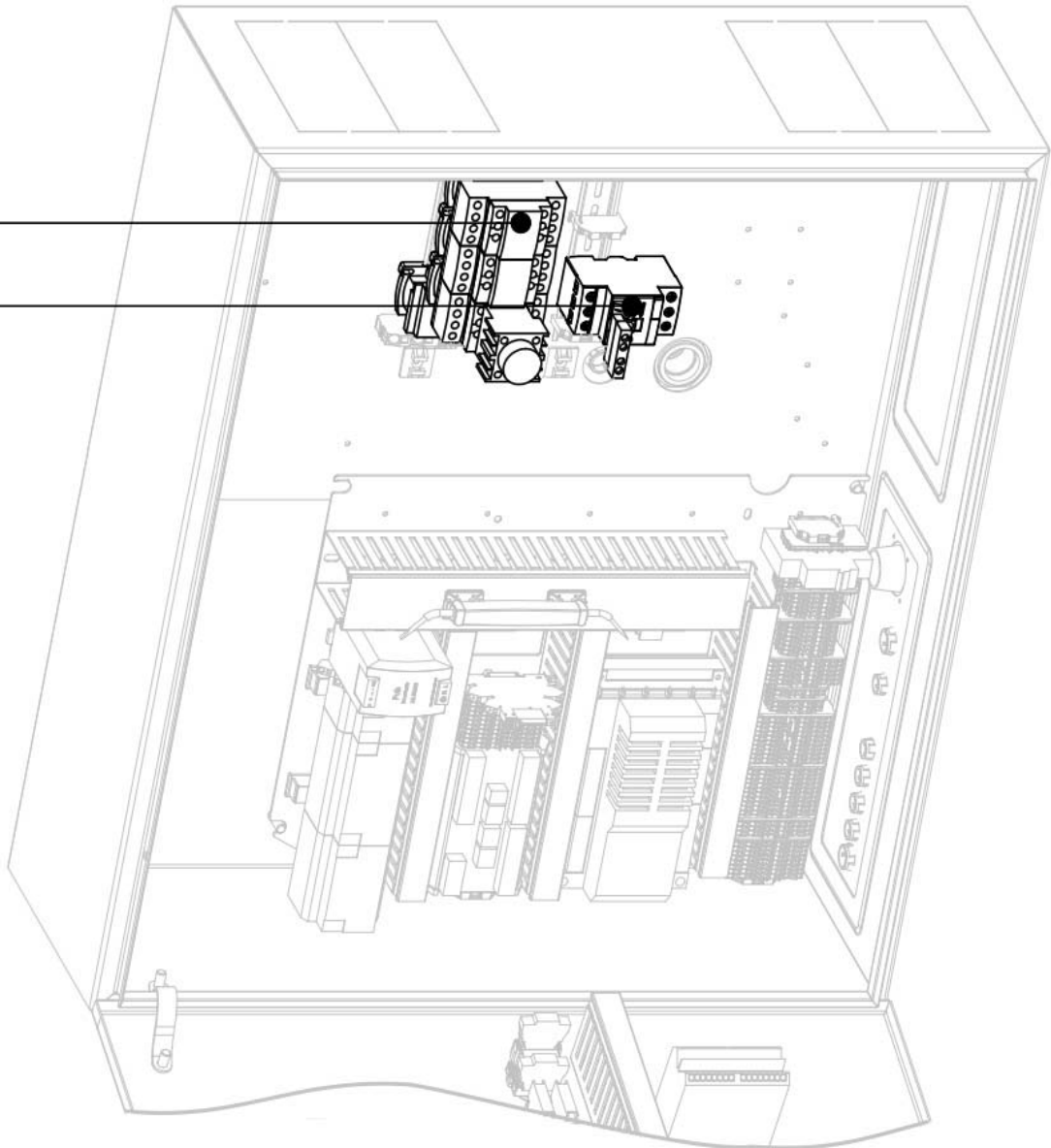

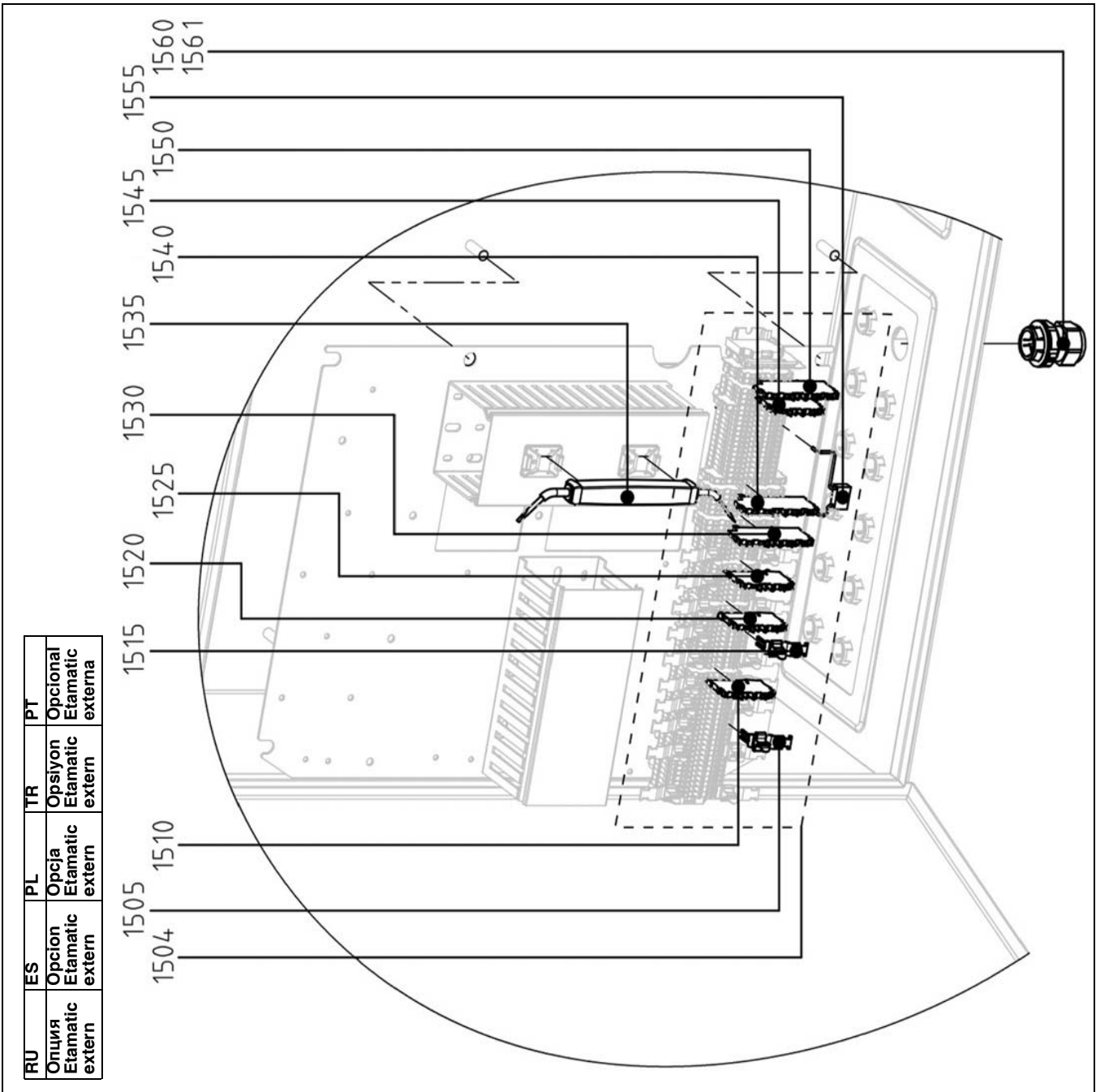

Pos.	Назначение	Denominación	Opis	Tanim	Designação
1860	Защитный выключатель двигателя вентилятора	Interrupitor de proteccion del motor del ventilador	Wyłącznik ochronny silnika dmuchawy	Fan motor koruma şalteri	Disjuntor-protetor do motor do ventilador
1861	Главный контроллер	Interrupitor auxiliar	Łącznik pomocniczy	Yardımcı şalter	Comutador auxiliar
1865	Стартер двигателя вентилятора	Cebador del motor del ventilador	Rozrusznik silnika dmuchawy	Fan motoru başlatıcısı	Arrancador do motor do ventilador

Pos.	Art. Nr.
1504	N6/N7
1505	N6/N7
1510	N6/N7
1515	N6/N7
1520	N6/N7
1525	N6/N7
1530	N6/N7
1535	N6/N7
1540	N6/N7
1545	N6/N7
1550	N6/N7
1555	N6/N7
1560	N6/N7 - CLICK M16
	N6/N7 - CLICK M20
	N6/N7 - CLICK M25
1561	N6/N7 - CLICK M16
	N6/N7 - CLICK M20
	N6/N7 - CLICK M25



RU	ES	PL	TR	PT
Опция Etamatic extern	Orsion Etamatic extern	Orcja Etamatic extern	Orsion Etamatic extern	Opcional Etamatic externa

Pos.	Назначение	Denominación	Opis	Tanım	Designação
1504	Клеммная колодка	Regleta de bornes	Listwa zaciskowa	Terminal bloğu	Bloco terminal
1505	Вставная ножка EMV 3-6 мм	Pie de sujeción (CEM) 3-6 mm	Stopka wtykowa EMC 3-6 mm	EMV çatal ayak 3-6 mm	Pé de encaixe CEM 3 – 6 mm
1510	Проходная клемма оранжевая 2-кратная	Borne de paso naranja doble	Zacisk przelotowy pomarańczowy podwójny	Devre terminali, turuncu 2 gözlü	Borne de passagem Laranja 2 cond.
1515	Вставная ножка EMV 6-8 мм	Pie de sujeción (CEM) 6-8 mm	Stopka wtykowa EMC 6-8 mm	EMV çatal ayak 6-8 mm	Pé de encaixe CEM 6 – 8 mm
1520	Проходная клемма серая 2-кратная	Borne de paso gris doble	Zacisk przelotowy szary podwójny	Devre terminali, gri 2 gözlü	Borne de passagem Cinzento 2 cond.
1525	Проходная клемма PE 2-кратная	Borne de paso PE doble	Zacisk przelotowy PE podwójny	Devre terminali, PE 2 gözlü	Borne de passagem PE 2 cond.
1530	Проходная клемма PE 4-кратная	Borne de paso PE cuadruple	Zacisk przelotowy PE poczwórny	Devre terminali, PE 4 gözlü	Borne de passagem PE 4 cond.
1535	Инструменты	Herramienta de accionamiento	Narzędzie do przełączania	İşletim aracı	Ferramenta de manobra
1540	Проходная клемма N 4-кратная	Borne de paso N cuadruple	Zacisk przelotowy N poczwórny	Devre terminali, N 4 gözlü	Borne de passagem N 4 cond.
1545	Проходная клемма N 2-кратная	Borne de paso N doble	Zacisk przelotowy N podwójny	Devre terminali, N 2 gözlü	Borne de passagem N 2 cond.
1550	Проходная клемма серая 4-кратная	Borne de paso gris cuadruple	Zacisk przelotowy szary poczwórny	Devre terminali, gri 4 gözlü	Borne de passagem Cinzento 4 cond.
1555	Пробная нагрузка ETAMATIC	Carga de ensayo ETAMATIC	Obciążenie próbne ETAMATIC	ETAMATIC test yükü	Carga de teste ETAMATIC
1560	Кабельный соединитель CLICK	Racor atornillado para cables CLICK	Połączenie gwintowane okablowania CLICK	CLICK kablo rakoru	Passa-cabos com parafuso CLIC
1561	Инструмент CLICK	Herramienta CLICK	Narzędzie CLICK	CLICK aracı	Ferramenta CLIC

	Условные обозначения	Leyenda	Legenda	Açıklama	Legenda
	Детали для технического обслуживания	Piezas de mantenimiento	Materiały eksploatacyjne	Bakım parçaları	Peças de manutenção
	Запчасти	Piezas de recambio	Części zamienne	Yedek parçalar	Peças de substituição
	Быстро изнашивающиеся детали	Piezas de desgaste	Części zużywające się	Aşınma parçaları	Peças de desgaste

# elco

---



**[www.elco.net](http://www.elco.net)**

Hergestellt in der EU. Fabriqué en EU. Fabricato in EU.  
Gefabriceerd in de EU. Made in EU.  
Angaben ohne Gewähr. Document non contractuel. Documento non contrattuale.  
Niet-contractueel document. Non contractual document.  
Произведено в ЕС. Fabricado en la UE. Wyprodukowano w UE. AB'de üretilmiştir.  
Fabricado na EU.  
Недоговорной документ. Documento no contractual. Niniejszy dokument nie ma  
charakteru umowy. Bağlayıcı olmayan doküman. Documento não contratual.