

**Operating Manual  
for professional installers  
Forced draught oil burner  
VECTRON B 40.420/460/590 DUO  
VECTRON B 45.810 DUO**

---

**elco**



# Overview

## Table of contents

---

	Page
<b>Overview</b>	Table of contents ..... 2
	Conformity declaration ..... 3
	Safety measures ..... 4
	Operator handover
	Installation maintenance, burner short description
	Intended use, symbols used
	Dimensions ..... 5
	Technical Specifications ..... 6
	Fields of application ..... 7
	Burner overview ..... 8/ 9
	<b>Function</b>
Oil pump ..... 10	
Servomotor air regulation, servomotor recirculation gap ..... 11	
Automatic burner controller ..... 12	
Electrical connection, oil connection ..... 13	
<b>Assembly</b>	
Mounting the boiler to the burner ..... 14	
Equipment panel service position, push bar adjustment ..... 15	
Flame tube mounting	
Oil nozzle selection and installation, ignition electrodes inspection .... 16	
Equipment panel installation, nozzle position adjustment ..... 17	
<b>Commissioning</b>	
Oil and electrical connections ..... 18	
Recommendations for combustion efficiency measurement	
Guidelines for recirculation gap adjustment	
Three-phase motors rotation direction	
Recommended settings ..... 19	
Burner adjustment ..... 20	
Air pressure monitor adjustment	
<b>Maintenance</b>	
Operating controls ..... 21	
Final inspection	
Maintenance operation	
Operating faults ..... 22	
Automatic burner controller displays ..... 23	
<b>Circuit diagram</b>	
Circuit diagram VB40.420D ..... 24	
Circuit diagram VB40.460/590D; VB45.810D ..... 25	

# Overview

## Conformity declaration

---

### Declaration of conformity CE

### Declaration of compliance D.R. 17/07/2009 - BE

Manufacturer SPM INNOVATION SAS  
2, avenue Josué Heilmann  
Z.I. de Vieux-Thann  
F - 68800 Vieux-Thann

 33 3 89 83 63 00

 33 3 89 83 63 07

Issued by See end of notice.

We hereby certify that the range of equipment specified below is in accordance with the format stated in the EC declaration of conformity, that it is manufactured and distributed in accordance with the regulations and requirements in european directives and with the regulations and requirements defined in the Royal Decree dated 17/07/2009.

Product type Fuel oil burner

Model VECTRON B40(45)

Applied standards Royal Decree dated 17/07/2009  
BlmSchV 2010  
Standards EN267  
2004/108/EC Electromagnetic Compatibility Directive  
Reference Standards: EN 55.014 - EN 61000  
2006/95/EC Low Voltage Directive  
Reference Standards: EN 60.335

Inspecting organisation TÜV Rheinland/Berlin-Brandenburg  
- OB 172 2012 Z2 - 19/10/2012  
- OB 39 2012 Z3 - 19/10/2012  
- OB 80 2012 Z4 - 19/10/2012

Measured values NOx < 88 mg/kWh; CO < 30 mg/kWh

Date: 11/2014

Signature  
Chairman  
Mr Maurice LOCATELLI



# Overview

## Safety measures, operator handover, installation maintenance, burner short description, intended use, symbols used

---

### Safety measures

- The installation must be carried out in accordance with applicable laws.
- In all cases, applicable safety regulations and accident prevention measures must be observed.
- Burner assembly, commissioning, operation and maintenance (inspection, repair) must be performed by qualified, suitably trained personnel
- The manufacturer alone is qualified to carry out repair work to electrical elements, flame monitoring equipment, and other safety equipment.
- It is forbidden to carry out changes or modifications, that are not specified in this manual. This can cause serious burner malfunctions.
- All works, with the exception of burner adjustment, may be carried out only after disconnecting the power supply.
- We accept no liability for any damages or faults identified, which are attributable to non-observance of these instructions.

 The combustion head and flame tube temperature remains at a high level, even after prolonged burner shut down. Handle with care .

### System handover to system operator

- During system handover, the installer will ensure that the operator is made particularly aware of those operations, which the operator himself will be required to carry out (burner fault, decommissioning). He must also clarify for the operator, the operations and modifications that may be carried out by qualified personnel only. He may refer to the "Operating Manual" which is attached to the burner.
- The operator must ensure that works to the burner are carried out by qualified personnel only.
- This manual forms part of the burner. Please store it safely in the boiler room, near to the appliance.

### Installation maintenance

To ensure optimal operation of your burner and to avoid operating faults, have the following works carried out by a professional on a yearly basis:

- Combustion head cleaning.
- Oil nozzle replacement.
- Electrodes replacement (where necessary).
- Boiler inspection and cleaning.
- Chimney inspection and cleaning.
- Boiler room fresh air supply inspection and cleaning.

### Burner short description

The VECTRON B 40/45-series burners are compact oil burners, the structure and function of which conform to burner standard EN267:

- They are supplied with cabling.
- They are fastened to the boiler by a sliding flange.
- All components are arranged on an equipment panel and easily accessible.
- The equipment panel provides optimal maintenance access.
- The flame is monitored by an infrared detector.
- Ignition takes place via an electronic transformer.

### Intended use

The VECTRON B 40/45 series burners are intended for firing of hot water boilers for heating buildings and/or domestic hot water.

For any other use, industrial processes, or specific applications, please contact us.

Fuel: European quality heating oil and low-sulphur heating oil (max. viscosity 6 mm<sup>2</sup>/s at 20 C).

In order to guarantee environmentally friendly operation, ensure optimum compatibility of the burner/boiler/flue gas design configuration. The flue gas system installation and design must be carried out in accordance with applicable guidelines and laws.

### Symbols used

 Caution danger!  
Risk of damage to persons and equipment. For the safety of persons and equipment, these instructions must be strictly observed.

 Note. These instructions will assist you in manoeuvring the burner

 Assembly phase

 Key figures

# Overview

## Dimensions

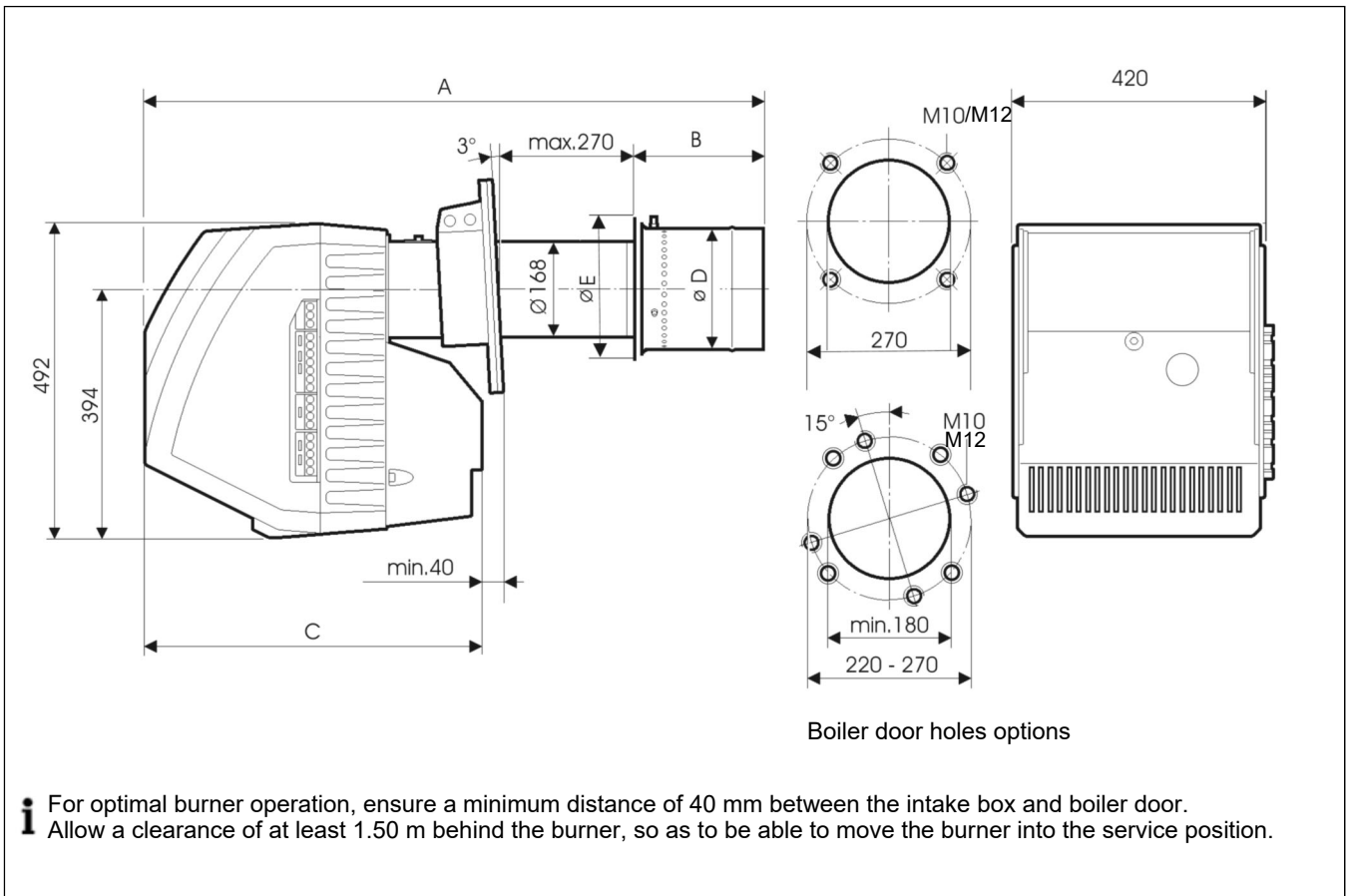

Burner type	Dimensions [mm]				
	A	B	C	$\varnothing D$	$\varnothing E$
VB40.420D	1176	255	611	210	300
VB40.460D	1176	255	611	210	300
VB40.590D	1206	285	611	250	300
VB45.810D	1291	330	651	280	330

### Flame head

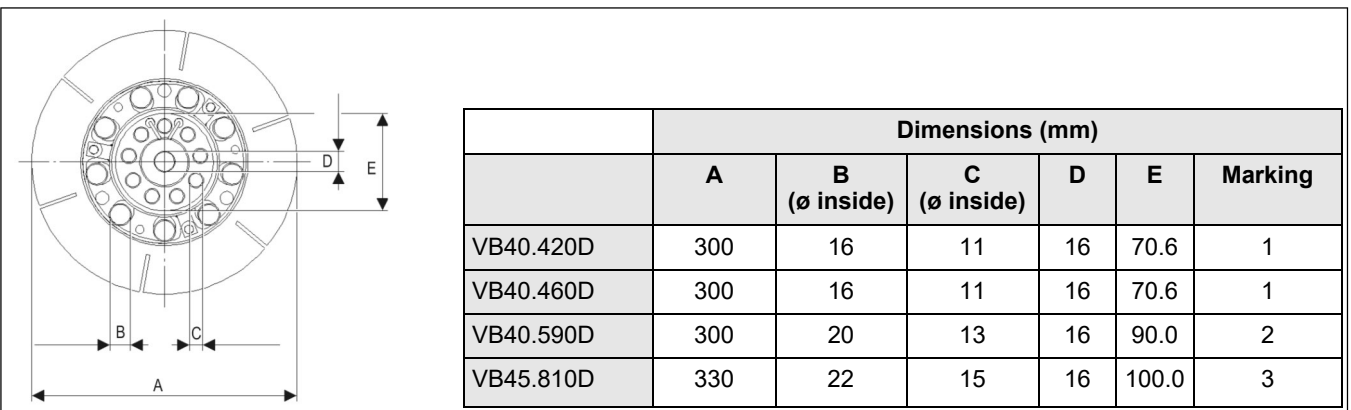

# Overview

## Technical Specifications

Burner	VB40.420D	VB40.460D	VB40.590D	VB45.810D
VKF approval no.	26125	26125	26125	26125
Operation	2-stage	2-stage	2-stage	2-stage
Performance range (EN267) [kW] <sup>(1)</sup> *	(136) 222-424	(140) 216-463	(232) 350-530	(290) 470-710(760)**
Oil flow (kg/h) <sup>(2)</sup> *	(11.5) 18.7 - 35.7	(11.8) 18.2 - 39.0	(19.8) 29,5 - 44,7	(24.5) 39.6 - 59,9 (64.1)**
Total input power	1280W	1450W	2050W	2480W
Rated power motor	750W/2580 min-1 230V-50 Hz	1100W/2580 min-1 400V-50 Hz	1100W/2580 min-1 400V-50 Hz	2200W/2800 min-1 400V-50 Hz
Noise level at 1 m (dBA)	69	69	70	74
Net weight (kg)	48	48	48	53
Gross weight (kg)	60	60	60	65
Nozzle marking (outer)	1	1	2	3
Nozzle marking (inner)	1	1	2	3

<sup>(1)</sup> Output at a height of 500 m over NN (Normal Null) and a temperature of 20°C. Fuel heating value: Hi = 11.86 kWh/kg.

<sup>(2)</sup> Fuel: Heating oil (max. viscosity 6 mm<sup>2</sup>/s at 20°C).

\* (Min. stage 1) min. stage 2 - max stage 2.

\*\* without deflector in air box.

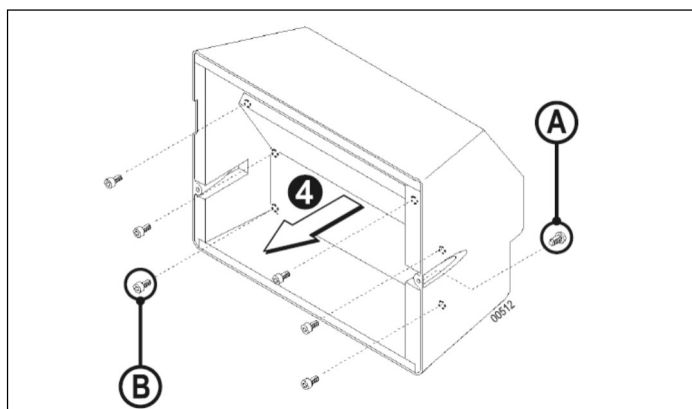

### For burner VB45.810D

For output from 809 kW (at 500m and at 20°C):  
Remove the deflector from the air box

- ➊ Unscrew screws **A** .
- ➋ Remove the air box.
- ➌ Unscrew the 6 air box screws **B** .
- ➍ Remove the deflector from the air box.
- ➎ Remount the air box.

# Overview

## Fields of application

### Performance curve according to standard EN 267

Burner output at a height of 500 m and a temperature of 20°C.

Performance loss at greater heights 1.45% per 100m. Fuel heating value:  $H_i = 11.86 \text{ kWh/kg}$ .

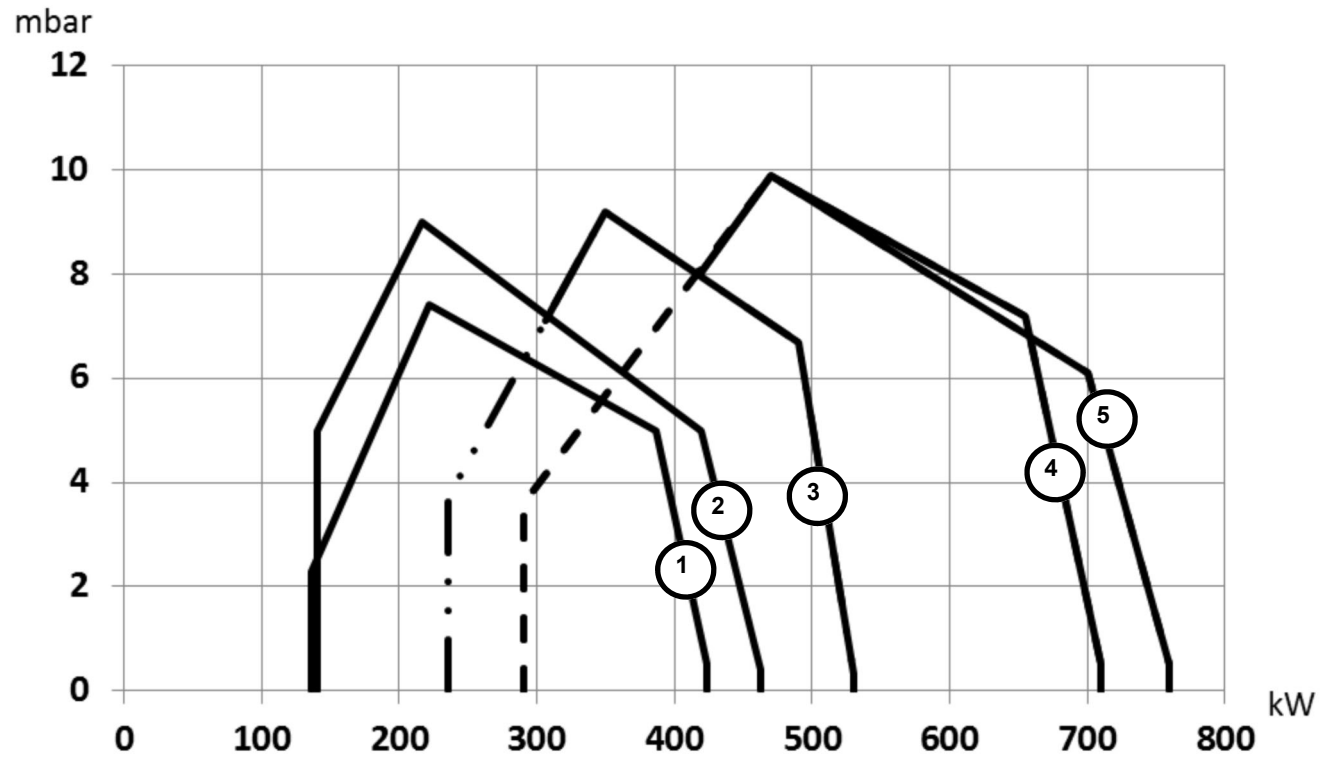

- ① VB40.420D    ② VB40.460    ③ VB40.590D    ④ VB45.810D (with deflector)    ⑤ VB45.810D (without deflector)

# Overview

## Burner overview VB40.420D

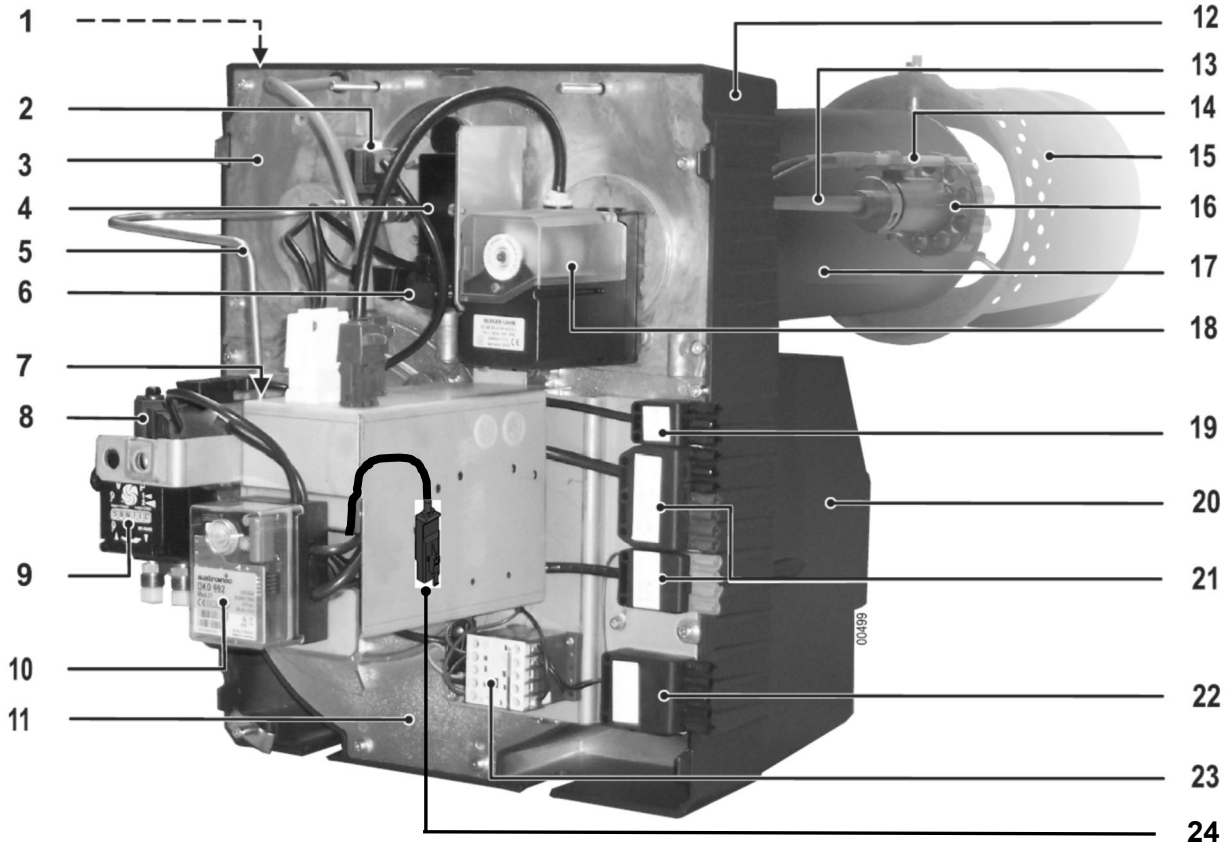

- |    |                              |    |                                     |
|----|------------------------------|----|-------------------------------------|
| 1  | Recirculation gap servomotor | 13 | Nozzle linkage                      |
| 2  | Solenoid valve               | 14 | Ignition electrodes                 |
| 3  | Upper equipment panel        | 15 | Flame tube                          |
| 4  | Ignition transformer         | 16 | Flame head (nozzle plate)           |
| 5  | Heating oil supply tube      | 17 | Burner tube                         |
| 6  | Flame monitor                | 18 | Air regulation servomotor           |
| 7  | Blower and pump motor        | 19 | Water conservation valve connection |
| 8  | Solenoid valves              | 20 | Air intake box                      |
| 9  | Oil pump                     | 21 | Connection to boiler                |
| 10 | Automatic burner controller  | 22 | Burner motor                        |
| 11 | Lower equipment panel        | 23 | contactor connection                |
| 12 | Housing                      | 24 | Remote unlock                       |

# Overview

## Burner overview VB40.460 / 590D VB45.810D

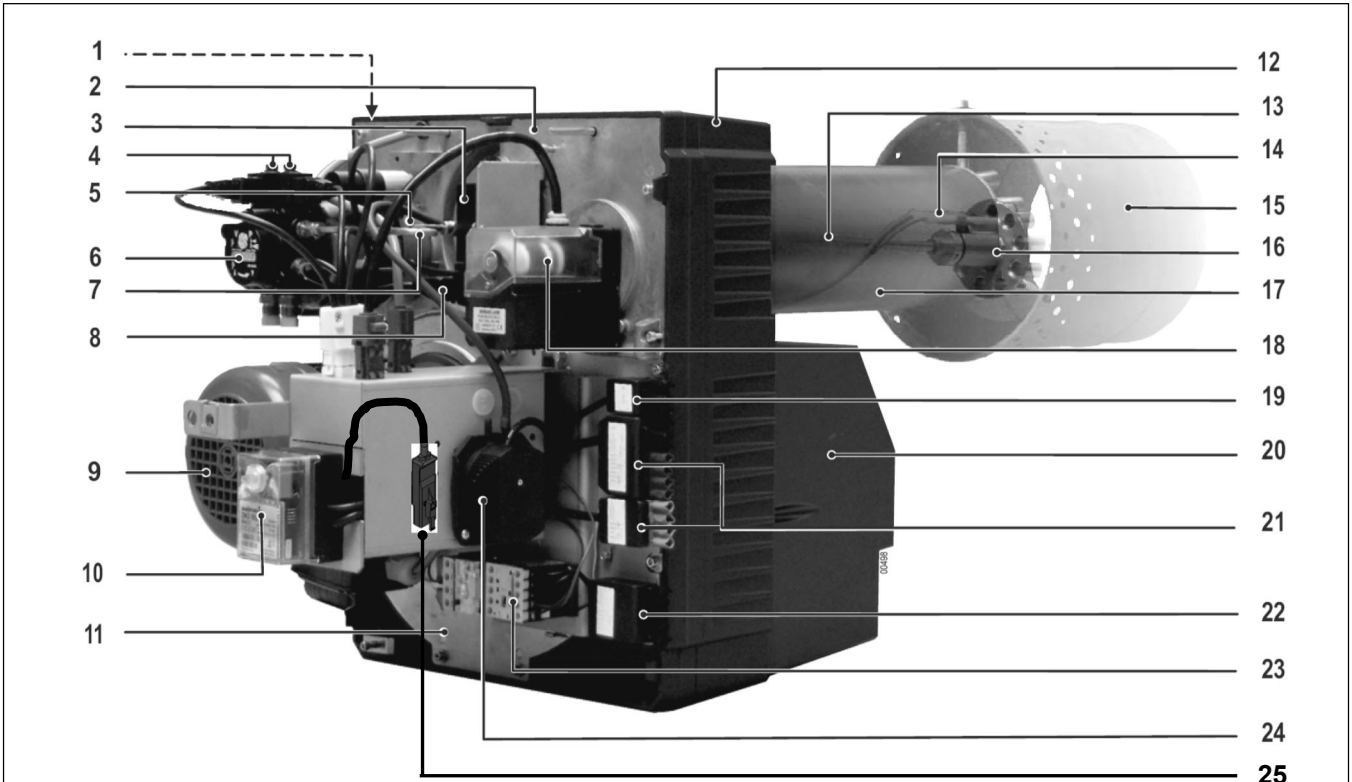

- |           |                              |           |  |
|-----------|------------------------------|-----------|--|
| <b>1</b>  | Recirculation gap servomotor | <b>13</b> | Nozzle linkage                                 |
| <b>2</b>  | Upper equipment panel        | <b>14</b> | Ignition electrodes                            |
| <b>3</b>  | Ignition transformer         | <b>15</b> | Flame tube                                     |
| <b>4</b>  | Solenoid valves              | <b>16</b> | Flame head (nozzle plate)                      |
| <b>5</b>  | Pump motor                   | <b>17</b> | Burner tube                                    |
| <b>6</b>  | Oil pump                     | <b>18</b> | Air regulation servomotor                      |
| <b>7</b>  | Heating oil supply tube      | <b>19</b> | Water conservation valve connection            |
| <b>8</b>  | Flame monitor                | <b>20</b> | Air intake box                                 |
| <b>9</b>  | Blower motor                 | <b>21</b> | Connection to boiler                           |
| <b>10</b> | Automatic burner controller  | <b>22</b> | Burner motor                                   |
| <b>11</b> | Lower equipment panel        | <b>23</b> | Contactor and motor contactor relay connection |
| <b>12</b> | Housing                      | <b>24</b> | Air pressure monitor                           |
|           |                              | <b>25</b> | Remote unlock                                  |

# Function

## Oil pump

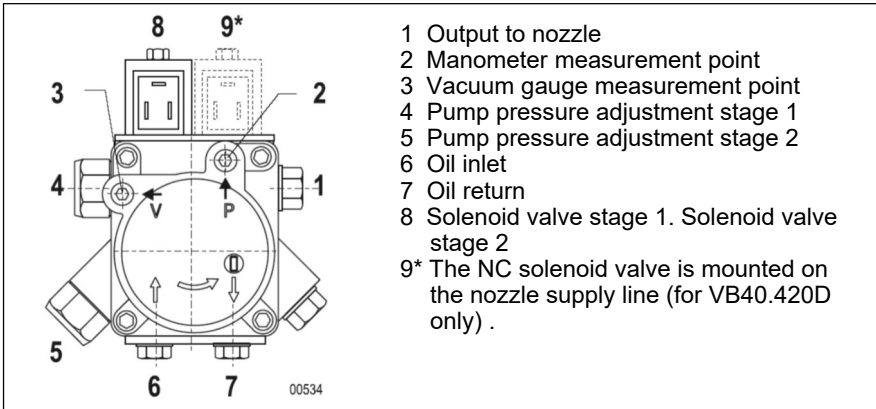

### Oil pump

The pump is a self-priming, clockwise-rotating gear pump (as viewed from the shaft side):

- It integrates a supply filter and an oil pressure regulator.
- The oil pump is connected to a vent filter via a two-pipe system.

**i** Vent the oil pump carefully during commissioning .

Burner	VB40.420D	VB40.460	VB40.590D	VB45.810D
SUNTEC oil pump	AP 265	AT 265	AT 275	AT 295
Ambient temperature (under the hood)	60 °C	60 °C	60 °C	60 °C
Pressure range stage 1	8 - 15 bar	8 - 15 bar	8 - 15 bar	8 - 15 bar
Pressure range stage 2	12 - 25 bar	12 - 25 bar	12 - 25 bar	12 - 25 bar
Max. negative pressure	0.45 bar	0.45 bar	0.45 bar	0.45 bar
Max. allowable supply pressure	2 bar	2 bar	2 bar	2 bar
Max. allowable return pressure	2 bar	2 bar	2 bar	2 bar
Pump intake flow at 10 bar	85 l/h	85 l/h	110 l/h	129 l/h
Pump intake flow at 25 bar	59 l/h	59 l/h	82 l/h	98 l/h

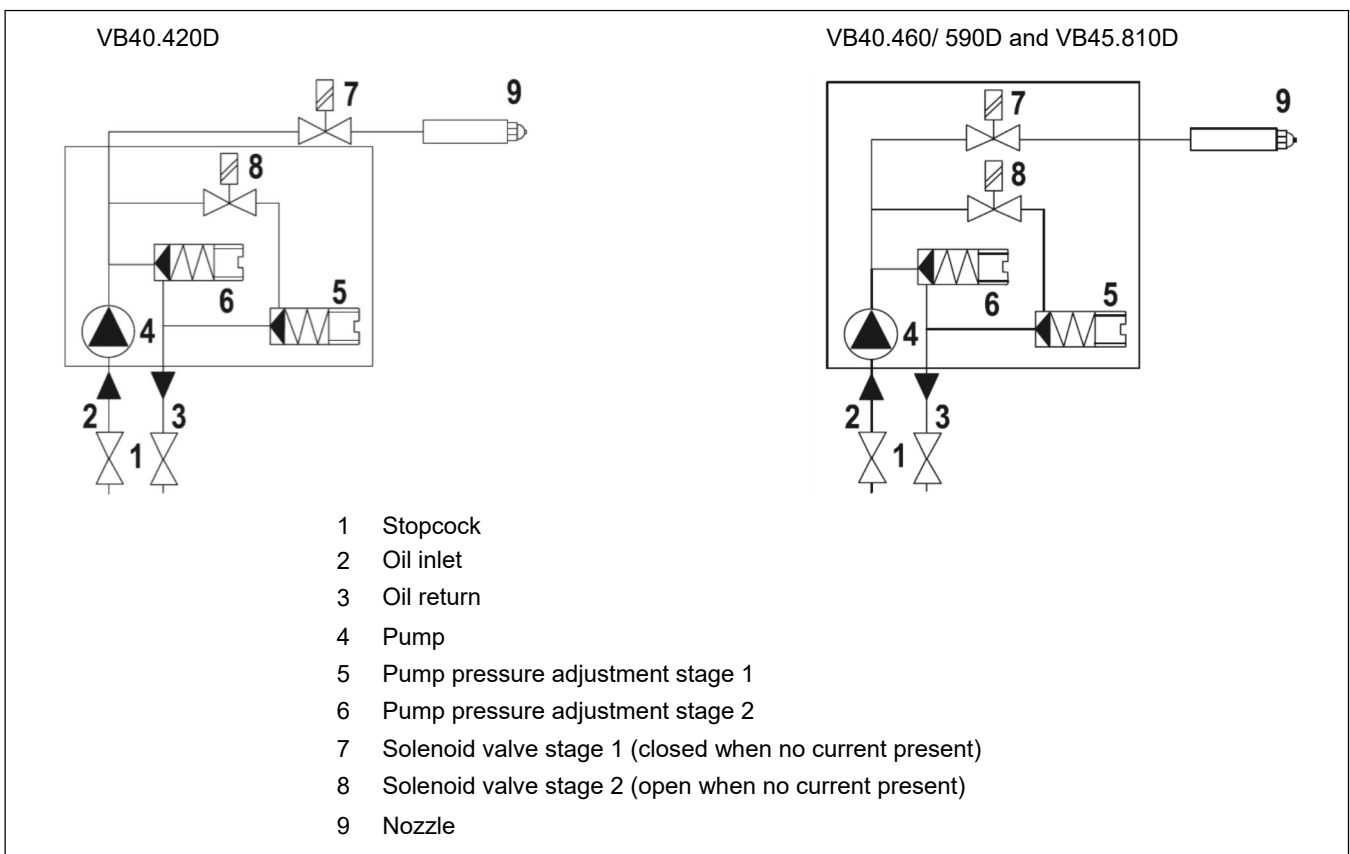

# Function

## Air regulation servomotor Recirculation gap servomotor



### Air regulation servomotor

- 1 Vent MV:**  
Solenoid valve opening stage 2
- 2 Vent ST0:**  
Exclusion of air
- 3 Vent ST2:**  
Air volume adjustment stage 2
- 4 Vent ST1:**  
Air volume adjustment stage 1

- i** • The servomotor controls opening of the air damper. To adjust air damper opening, use vents ST1 for partial load and ST2 for full load.
- Adjust vent ST0 to 0°.
- Adjust the MV vent between ST1 and ST2 (5° below ST2).
- Use the screws located on the vent for fine-tuning.

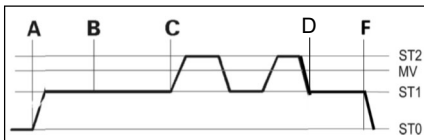

A	Burner start-up	C-D	Controller
A-B	Pre-aeration	D	Burner stop
B-C	Ignition	F	Post-aeration
C	Acceleration stage 2		

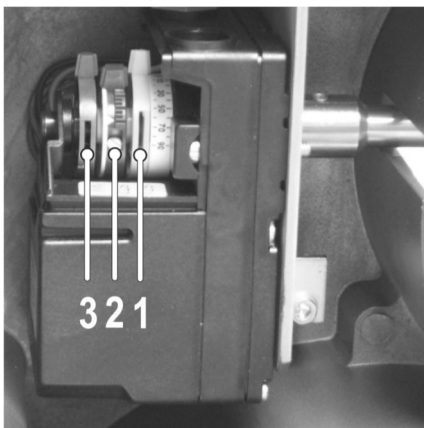

### Recirculation gap servomotor

The servomotor located in the upper left hand part of the burner can ensure optimal recirculation gap adjustment. Access is via the lid on top of the burner.

- 1 Vent I**  
Flame tube position at start-up
- 2 Vent II**  
Flame tube position during operation
- 3 Vent III**  
Releases the 2 burner stages

- i** Adjust vent III to between I and II (5° below II)

# Function

## Automatic burner controller

### Automatic burner controller DKO 992 - N Operating cycle

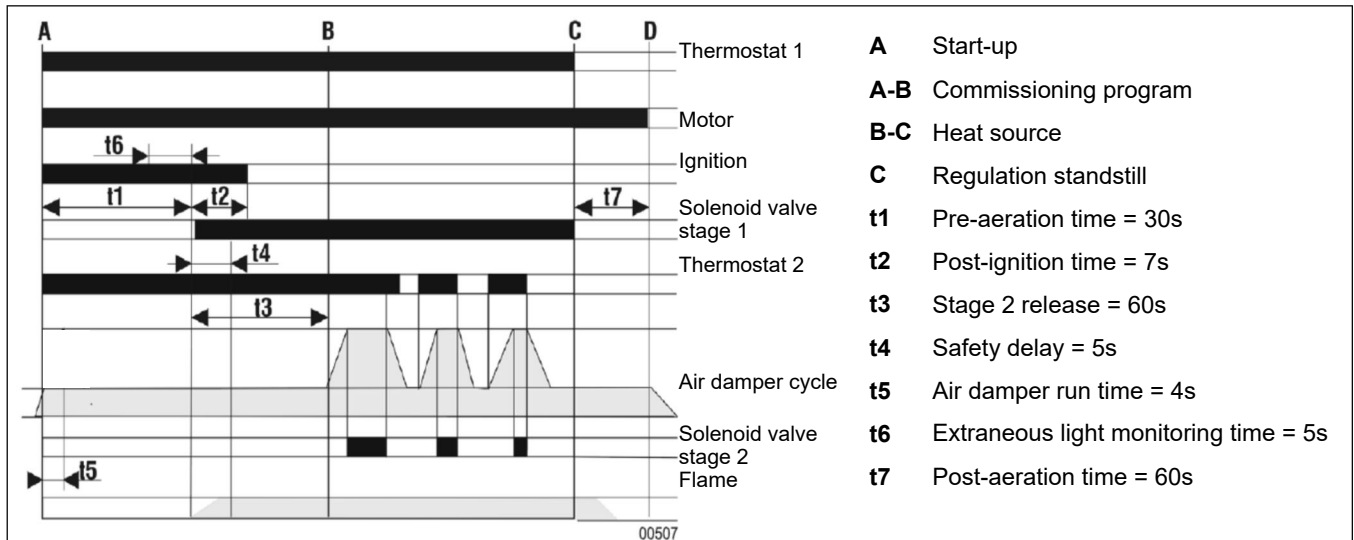

**⚠** The automatic burner controller may be connected to the socket or disconnected from the socket, only when the master power switch of the heating system is switched off.  
The automatic burner controller is a safety device and must not be opened.

### Operation and fault displays

The automatic burner controller is controlled by a microprocessor.

During normal burner operation, a blink signal indicating burner operation status is displayed every 5 seconds via the light-emitting diode (LED). Between blink signals, the LED is off.

If a fault occurs, a blink signal is displayed every 10 seconds to indicate the error. Between blink signals, the LED is continually on.

A table showing the various blink signals can be found in the "Maintenance" chapter.

Further information can be read via optional accessory communication software.

# Function

## Electrical connection Oil connection

---

### Electrical connection

 A manually operated circuit breaking device must be used to isolate the system during maintenance, cleaning and repair work. It must simultaneously disconnect all ungrounded lines from the mains supply. This circuit breaker is not supplied. The burner is supplied ready for operation with a single-phase mains voltage of 230 V - 50 Hz. This burner does not require a thermal relay.  
For the separate power supply, a 10AT fuse is required.

 Before carrying out any operation on the burner, it must be disconnected from the mains. The installation and connections must be carried out in accordance with applicable standards. Ensure that the grounding is correct.

 The connecting cables are equipped with standard DIN 4791 connectors.

### Connecting a water conservation valve

The burner is equipped with a connector for connecting a water conservation valve, in the heating oil supply between burner and tank. (See applicable legislation).

 **Adhere to electrical wiring diagram.**

### Connecting a remote unlock

The burner is equipped with a plug for connection of a remote unlock.

 **Adhere to electrical wiring diagram.**

### Oil connection

The burner is supplied for heating oil connection in the two-pipe system, between the oil pump and a vent filter. The use of a single-pipe system between the filter and the pump is not recommended.

To avoid contamination of the nozzle, a filter (mesh size 80µm to 150µm) must be installed in the heating oil inlet.

It is recommended that you install a single-line system between the tank and vent filter.

Heating oil supply is to be carried out in accordance with applicable standards. It is important to ensure that supply pressure loss is low (elbow joints, dimensioning, etc.).

 We recommend the use of a combination fuel oil filter—deaerator.

# Assembly

## Mounting the boiler to the burner

- ① Mount seal and sliding flange at mounting position **A** on the boiler door.
- ② Tighten lower screws, leave upper screws loose.
- ③ Spread burner flange by tightening screw **B**.
- ④ Loosen flame tube plate fastening screws and spacer on combustion head. Remove the flame tube plate with spacer.
- ⑤ Remove equipment panel from housing (to do this, see service position on page 15). Carefully put the equipment panel to one side (do not hang in the housing).
- ⑥ Separate the spherical head of the push bar from the servomotor recirculation gap shaft.
- ⑦ Slide the push bar forward and turn the 3 retaining bolts on the flame tube inward and fasten.
- ⑧ Slide the burner with burner tube into the burner flange.
- ⑨ Seal any gap between the burner tube and boiler door insulation with fireproof insulating material.
- ⑩ Apply heat resistant grease to the flame tube plate fastening screws and the intermediary ring, and mount both parts.
- ⑪ Position the burner in such a way, that the flame tube plate rests on the boiler door insulation.
- ⑫ Loosen screw and tighten the top fastening screws on the burner flange.
- ⑬ Continue assembly with push bar adjustment and flame tube mounting (page 15).

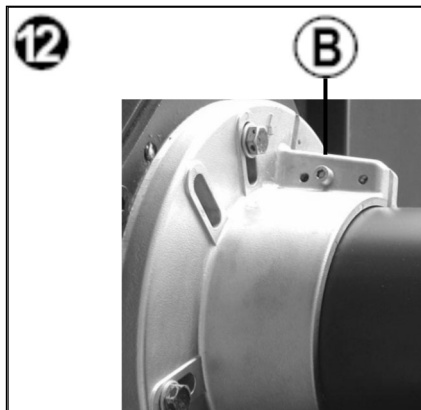
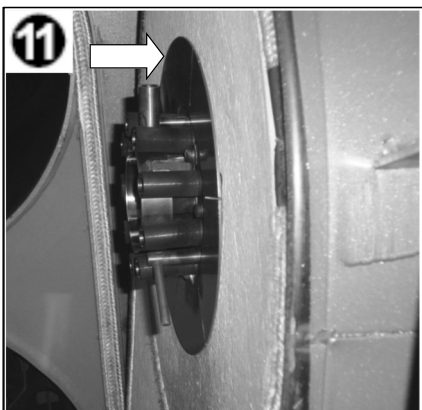
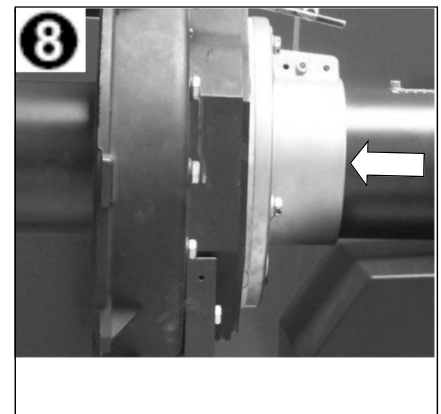
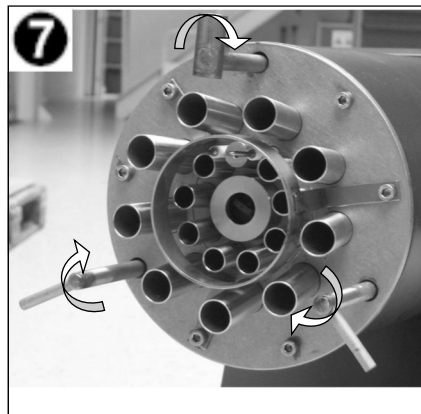
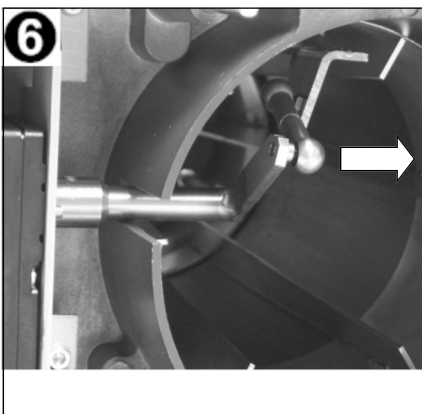
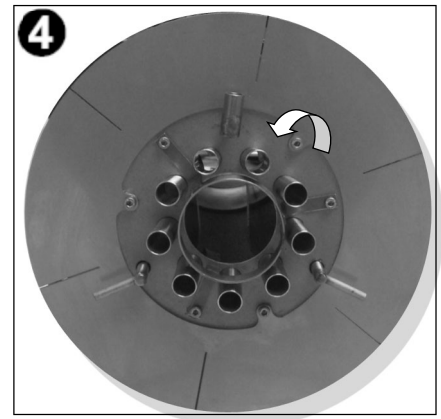
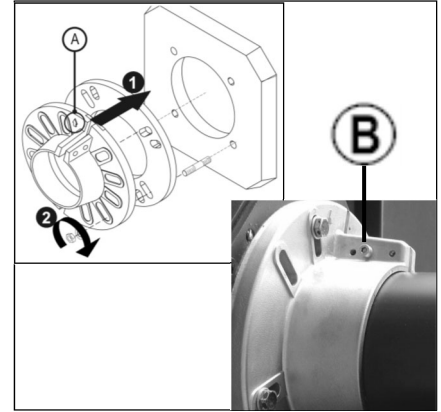

# Assembly

## Equipment panel service position Push bar adjustment Flame tube mounting

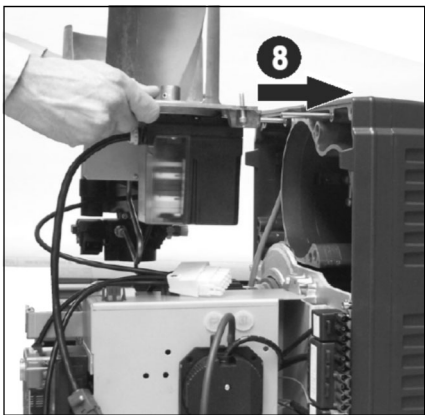
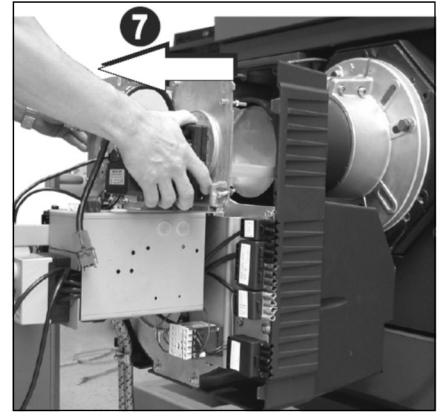
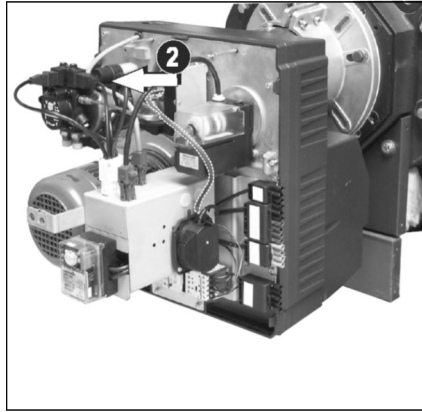
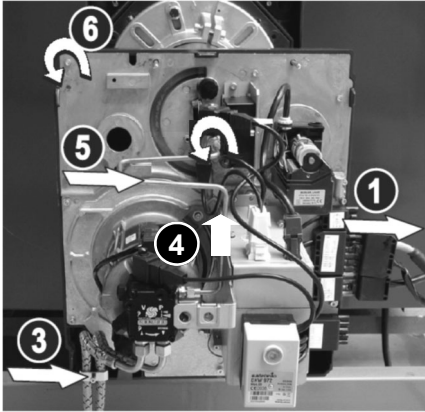

- ❶ Disconnect all burner electrical connections (4-/7-pin from boiler as well as external motor power supply) from the burner.
  - ❷ Remove compressed air hose (VB40.460/590D and VB45.810D only).
  - ❸ Loosen clamp on oil hoses (VB40.460/590D and VB45.810D).
  - ❹ Disconnect flame monitor/ignition transformer (white) and servomotors (red) plugs.
  - ❺ Loosen heating oil supply tube and rotate 90° (VB40.420D only).
  - ❻ Loosen the 6 screws.
  - ❼ Remove upper plate.
  - ❽ Attach the equipment plate to the housing, ensuring that the plate recesses are placed on the housing positioning screws.
- i** Avoid any mechanical strain on the blower wheel. Under no circumstances must the blower wheel be used for storage. This could cause bending.

### Recirculation gap effect

The proportion of recirculation gas depends on the recirculation gap. This exerts a direct influence on the NOx level. If the recirculation gap is large, the NOx content is low. As a result, however, flame stability deteriorates. The recirculation gap must be adjusted, so that the lowest possible NOx levels are achieved, with a stable flame.

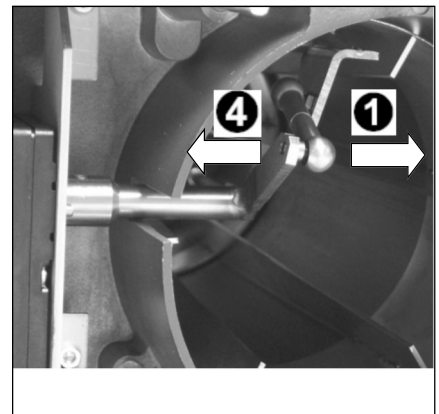
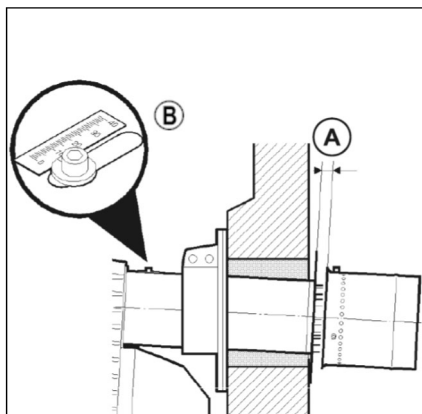

### Push bar adjustment

- i** With the servomotor recirculation port at the zero position, the push bar is factory set at scale value 5 on scale **B**. If correction is required, proceed as follows:
- ❶ Separate the spherical head of the push bar from the servomotor shaft.
  - ❷ Screw or unscrew the spherical head.
- One rotation corresponds to approximately 0.8 scale values.
- ❸ Reattach the spherical head to the servomotor shaft.

### Flame tube mounting

- ❶ Separate the spherical head of the push bar from the servomotor shaft.
- ❷ Slide the push bar forward and turn retaining bolts outward.
- ❸ Mount the flame tube on the retaining bolts.
- ❹ Reattach the spherical head of the push bar and check the width of the gap.

- i** For homogeneous recirculation and optimal flame stability on start-up: 5 mm gap width over the entire circumference **A** of the flame tube.
- ❺ If necessary, dismantle the flame tube again and adjust the recirculation gap by screwing or unscrewing the retaining bolts to the corresponding position.
- One rotation of the retaining bolts corresponds to a displacement of 0.8mm.
- i**

# Assembly

## Oil nozzle selection and installation Ignition electrodes inspections

### Oil nozzle selection

The best combustion results are generally achieved with a Delavan 80°A type nozzle. Determine the nozzle size corresponding to the burner output desired, using the settings table on page 19.

### Installing the heating oil nozzle

- ❶ Extract the insert (A) (click closure).
- ❷ Remove the cap.
- ❸ Screw in the nozzle.
- ❹ Latch the insert (A) on to the burner head.

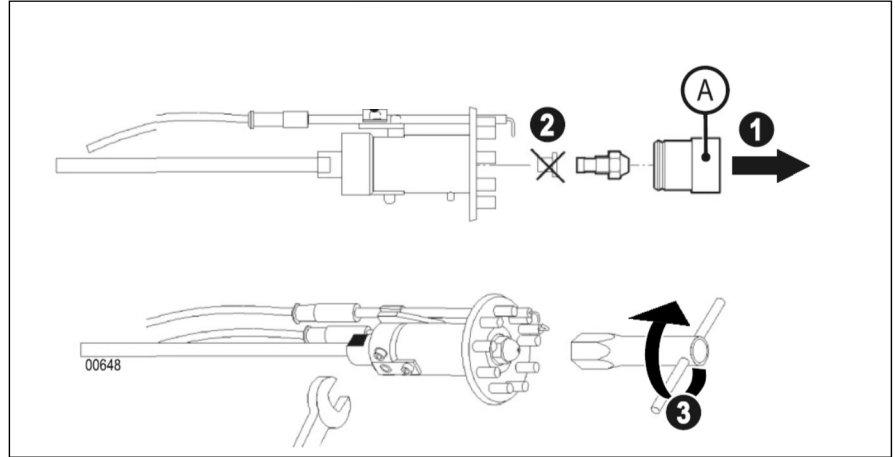

### Ignition electrodes positioning inspection

Burner type	ⓓ (mm)
VB40.420D	23
VB40.460D	23
VB40.590D	26
VB45.810D	30

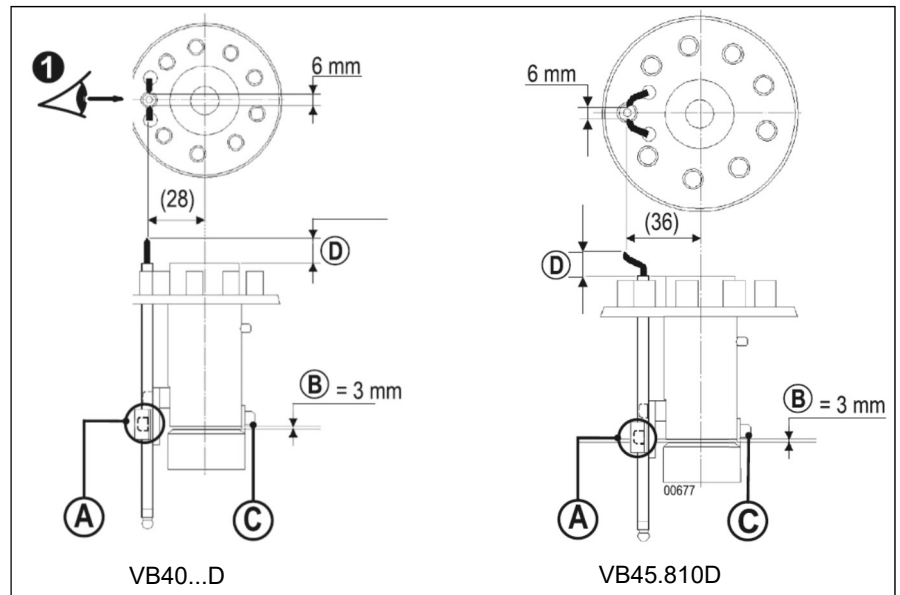

- ❶ Check the dimensions indicated in the above drawing.
- ❷ To change the position of the ignition electrodes, loosen locking screw (A).
- ❸ Align the ignition electrodes with the nozzle opening axle.
- ❹ Wrap the ignition cables around the nozzle linkage. Connect the ignition electrodes cable.
- ⓘ To avoid problems with flame monitoring, ensure that the flame monitor is not covered.
- ❺ Check dimensions (B). Adjust the value using screw (C) if necessary.

# Assembly

## Equipment panel installation Nozzle position adjustment

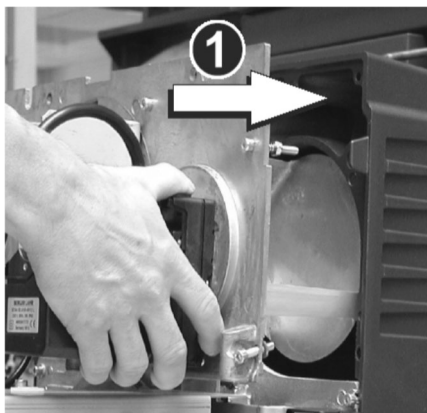

### Equipment panel installation

- ⚠ Apply high temperature grease to the outer rim of the nozzle plate.
- ➊ Carefully insert the nozzle linkage into the flame tube.
- ➋ Attach the burner equipment plate on to the housing.
- ➌ Tighten the 6 screws.
- ⓘ The two screws (A) located on the housing are provided as a guide for positioning the equipment panel.
- ➍ Connect compressed air hose (VB40.460/590D and VB45.810D only).
- ➎ Connect flame monitor/ignition transformer (white) and servomotors (red) plugs.
- ➏ Connect heating oil supply tube (VB40.420D only)

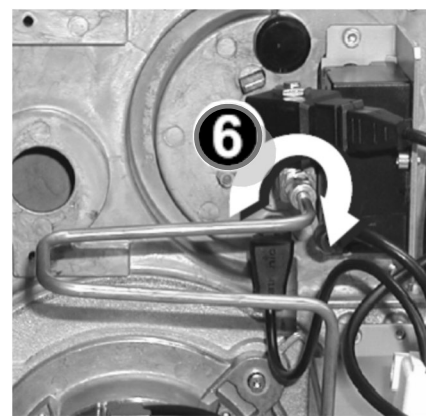
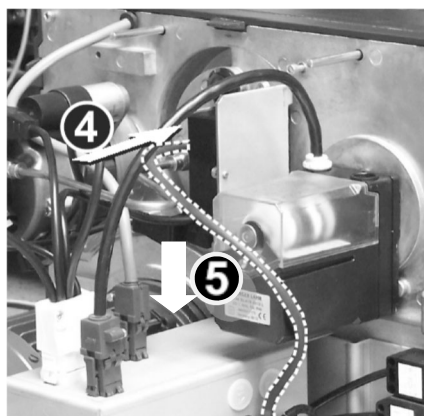
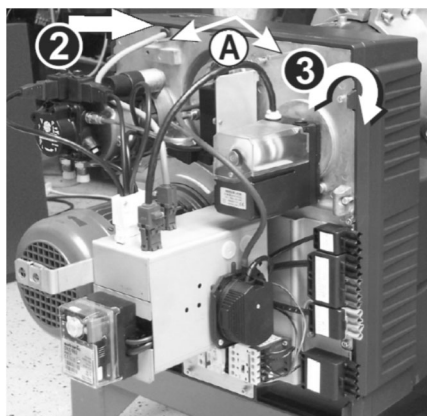

### Nozzle position adjustment

- ➐ Check dimensions. Adjust the value using screw (B) if necessary.
- ⓘ Check and correct the nozzle position, each time it is replaced.

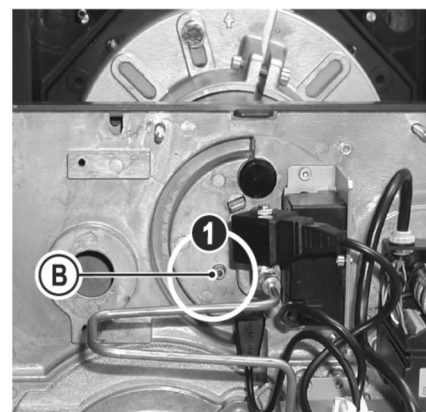
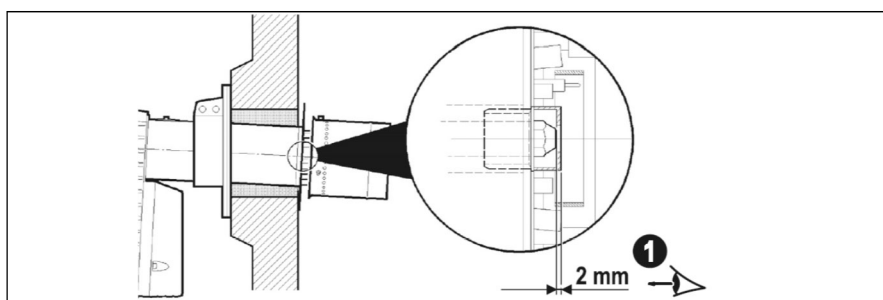

# Commissioning

## Oil and electrical connections

### Recommendations for combustion efficiency measurement

### Guidelines for recirculation gap adjustment

### Three-phase motor rotation direction

#### Oil and electrical connections

 For safety reasons, we recommend that you do not connect the oil or power supplies prior to commissioning.

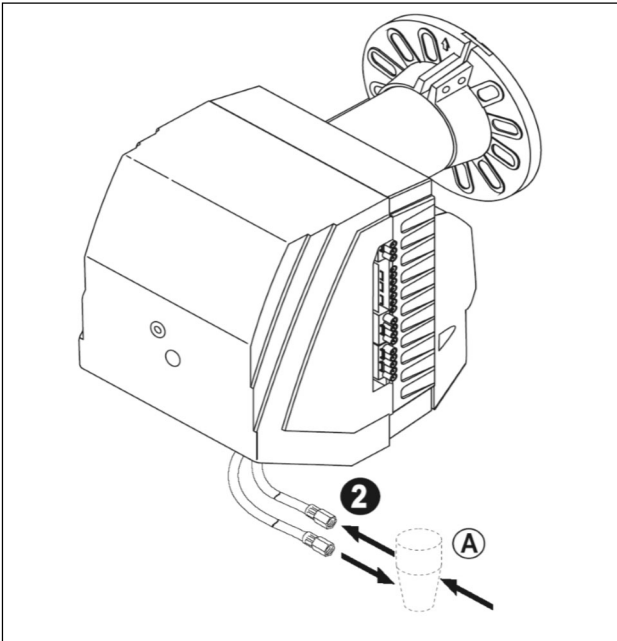

- 1 Secure the fuel hoses in their row clamp.
- 2 Connect the burner oil hoses to the oil supply.
- 3 Position the cable on the equipment panel and press firmly into the lug provided.
- 4 Connect the electrical plugs.
- A Oil filter.

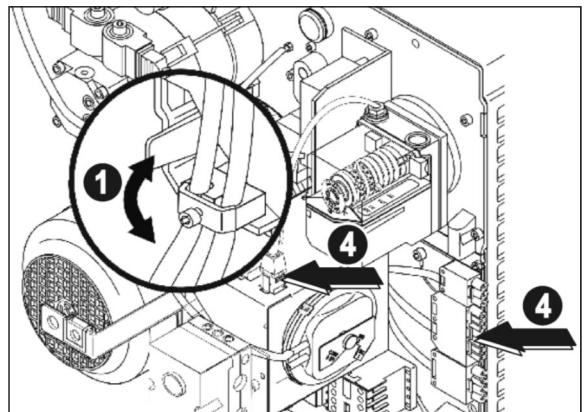

#### Recommendations for combustion efficiency measurement

-  Carefully adjust the burner, so that it meets locally applicable emission regulations.
- The flue gas circuit between the chimney and the boiler flue outlet must be tightly sealed to prevent measurement errors.
- To carry out combustion measurements, adhere to burner running time:
- 5 min. operation (boiler heated)
  - 10 min. operation (boiler cold).

When burner installation and adjustment is complete:

- Check soot index.
- Check smoke emissions values.

 In order to avoid flame monitoring problems at low power, adhere to the recommended settings.

#### Guidelines for recirculation gap adjustment (during operation)

-  The proportion of recirculation gas depends on the recirculation gap. This exerts a direct influence on the NOx level. If the recirculation gap is large, the NOx content is low. As a result, however, flame stability deteriorates. The recirculation gap must be adjusted, so that it achieves the lowest possible NOx levels, with a stable flame.
- Adjusting the recirculation gap via the "recirculation gap" servomotor vents:

#### If the recirculation gap is too small:

- Increase vent II value.
- Check combustion.

#### If the recirculation gap is too large:

- Switch burner off.
- Decrease vent II value.
- Start the burner
- Check combustion.

 Adjust vent III to between I and II.

#### Three-phase motor rotation direction

-  On three-phase motors (VB40.460/590D, VB45.810D), check the rotation direction of the blower motor. Make sure that the motor rotates in the direction of the arrow marked on the motor.

 The motor contactor relay switch must be in position H (A: Automatic - H: Hand).

# Commissioning

## Recommended settings

### Recommended settings for condensing boilers with increased combustion chamber back pressure (e.g. STRATON XL)

Burner	Burner output <sup>(1)</sup> [kW]	Nozzle Delavan 80°A [GPH]	Oil pressure <sup>(1)</sup> [bar]	Servo- motor Air regulation <sup>(1)*</sup> (ST1/ST2)	Servo- motor Recirculation gap <sup>(1)**</sup> (I/II)	Recirculation gap Start/operation [mm]	Air pressure at Burner head <sup>(1)</sup> [mbar]	Combustion chamber pressure [mbar]	Value CO <sub>2</sub> <sup>(1)</sup> [%]
VB40.420D STRATON XL 350	230 / 325	5,50	10 / 20	40 / 55	0 / 25°	5 / 20	10,3 / 19,2	1,8 / 3,6	12/13
	230 / 340	5,50	10 / 22	40 / 60	0 / 25°	5 / 20	10,3 / 20,0	1,8 / 3,8	
VB40.460D	235 / 360	5,50	10 / 24	20 / 40	0 / 25°	5 / 20			
	295 / 435	7,00	10 / 22	25 / 110	0 / 25°	5 / 20			
VB40.590D STRATON XL 450	280 / 435	6,50	10 / 24	12 / 40	0 / 50°	5 / 35	7,5 / 18,0	1,8 / 4,2	
	290 / 450	7,00	10 / 23	15 / 50	0 / 50°	5 / 35	8,0 / 18,5	2,0 / 4,5	
VB45.810D STRATON XL 600	410 / 610	9,50	10 / 23	30 / 60	0 / 60°	5 / 40	12,9 / 22,2	3,5 / 7,2	

- i** <sup>1)</sup> Stage 1 / Stage 2  
 \* Adjust the MV vent between ST1 and ST2 (5° below ST2).  
 \*\* Adjust vent III to between I and II (5° below II).

### Recommended settings for low-temperature boilers with chimney draft

Burner	Burner output <sup>(1)</sup> [kW]	Nozzle Delavan 80°A [GPH]	Oil pressure <sup>(1)</sup> [bar]	Servomotor Air regulation <sup>(1)*</sup> (ST1/ST2)	Servomotor Recirculation gap <sup>(1)**</sup> (I/II)*	Recirculation gap Start/operation [mm]	CO2 value <sup>(1)</sup> [%]
VB40.420D	140 / 220	3.5	10 / 25	13 / 25	0 / 15°	5 / 13	12 / 13
	190 / 295	4.5	10 / 24	20 / 40	0 / 20°	5 / 18	
	250 / 380	6.0	10 / 22	30 / 90	0 / 25°	5 / 20	
VB40.460D	190 / 295	4.5	10 / 20	15 / 20	0 / 25°	5 / 20 (max. 40 mm)	
	235 / 360	5.5	10 / 24	20 / 40	0 / 25°		
	295 / 435	7.0	10 / 22	25 / 110	0 / 25°		
VB40.590D	235 / 360	5.5	10 / 24	15 / 30	0 / 50°	5 / 35 (max. 40 mm)	
	270 / 435	6.5	10 / 24	20 / 45	0 / 50°		
	360 / 535	9.0	10 / 21	35 / 90	0 / 50°		
VB45.810D	290 / 475	7.0	10 / 25	10 / 20	0 / 60 <sup>^</sup>	5 / 40 (max. 40 mm)	
	395 / 630	9.5	10 / 23	20 / 45	0 / 60°		
	465 / 715	11.0	10 / 24	25 / 105	0 / 60°		
VB45.810D	575 / 760 <sup>***</sup>	13.0	11.5 / 21	35 / 105	0 / 60°		

- i** Grey fields: Factory setting  
<sup>(1)</sup> Stage 1 / Stage 2  
 \* Adjust the MV vent between ST1 and ST2 (5° below ST2).  
 \*\* Adjust vent III to between I and II (5° below II).  
 \*\*\* without deflector

# Commissioning

## Burner adjustment Air pressure monitor adjustment

### Adjusting the burner

- 1 Attach a manometer and vacuum gauge to the oil pump.
- 2 Adjust vent ST0 = 0°.
- 3 Adjust vents ST1 and ST2 for desired output.  
Vent MV must be adjusted to between ST1 and ST2 (5° below ST2).
- 4 Adjust recirculation gap servomotor vents "I" and "II". Vent "III" must be adjusted to between "I" and "II".
- 5 Only for IRD 1010: Adjust flame monitoring sensitivity to maximum (position 7).
- 6 Start the burner.
- 7 Check pressure at head (stage 2).
- 8 Adjust oil pump pressure (stage 2).
- 9 Adjust the CO<sub>2</sub> value for full load using vent ST2.
- 10 Drive the servomotor back and forth, to initialise vent ST2 position.
- 11 Adjust oil pump pressure (stage 1).
- 12 Check pressure at head (stage 1).
- 13 Adjust the CO<sub>2</sub> value for part load using vent ST1.
- 14 Drive the servomotor back and forth, to initialise vent ST1 position.
- 15 Measure combustion values and check flame stability.
- 16 Only for IRD 1010: Rotate the flame monitoring potentiometer until LED 1 blinks. Turn back 2 graduations, so that the 2 LEDs illuminate. If LED 1 does not flash, turn potentiometer to position 5.
- 17 Check burner start-up and part load/full load switching. Adjust vent MV (if necessary).
- 18 Copy the following settings into the "checklist" table of the operating manual.

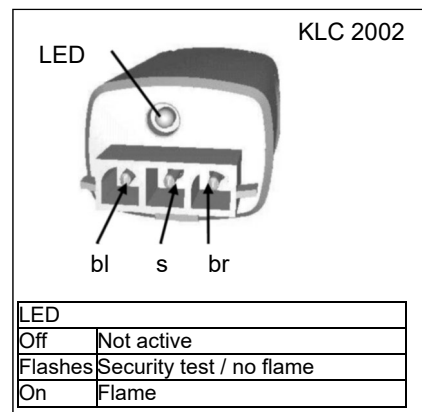
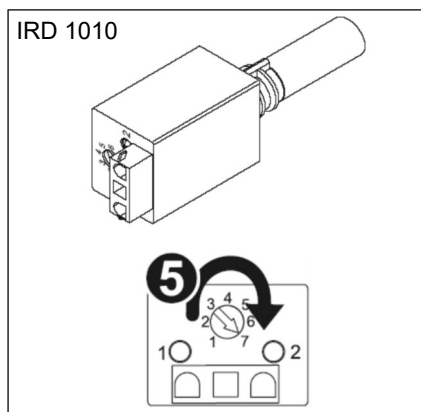
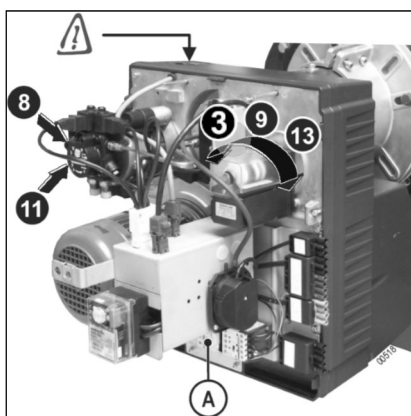

### Air pressure monitor adjustment (not VB40.420D)

- ⚠** The air pressure monitor in series VB40/45..D burners is factory set to 0.4mbar and cannot be changed.
- i** In the VB40.420D, the pump is mounted on the blower motor axle, and there is no air pressure limiter.

# Maintenance

## Operating controls Final inspection Maintenance operation

---

### Operating controls

During commissioning or after burner inspection, the following checks are to be performed:

Remove flame monitor, cover it, and start the burner.	➔	When the safety delay has elapsed, the automatic burner control must switch to fault. The burner switches off.
The burner is in operation: The flame monitor must be removed and covered.	➔	Start again. When the safety delay has elapsed, the automatic burner control must switch to fault.
Remove flame monitor, Expose to daylight, and start the burner.	➔	The automatic burner control must switch to fault after approximately 20 seconds of pre-aeration. The burner switches off.

---

### Final inspection

Start the burner several times and monitor the automatic burner control program execution.

Before the installer leaves the system, he must:

- Make sure that the boiler devices and the thermostats are working properly;
- Make sure that the thermostats are correctly adjusted;
- Check that the fresh air supply opening meets applicable standards;
- Fill in the check sheet on the reverse of the instruction manual;
- Record his name and service number on the instruction manual;
- Refer the operator to the instruction manual enclosed with this document, drawing his attention in particular to the "burner fault" paragraph;
- Hand over the instruction manual to the operator, and advise that the instructions are to be kept in the vicinity of the burner.

### Maintenance operation

The burner and boiler must be inspected and cleaned at least once a year.

Only qualified professional installers may carry out these works.



**A significant flue gas temperature increase means that the boiler is dirty and must be cleaned.**

1. Turn off the heating system master switch and disconnect the burner from the power supply.
2. Check the condition of the combustion chamber and exhaust gas routing. Clean if necessary.
3. Move the burner into the service position.
4. Check and clean the oil filter. Replace if necessary. Check the condition of the nozzle. Check the condition of the electrodes (replace annually if necessary). Check the fresh air inlet to the boiler room and clean.
5. Clean all burner elements (for suitable flame head cleaning agents, see spare parts list).
6. Replace faulty parts.
7. Move the burner into the operating position.
8. Mount the manometer and vacuum gauge to the burner pump.
9. Check the electrical connections of the burner. Turn on the system master switch.
10. Start the burner. Adjust burner.
11. Carry out combustion measurements (boiler in operation).
12. Enter the measurement results and the material replaced on the check sheet, located on the reverse of the instruction manual.
13. Carry out a functional final inspection and a final inspection.

# Maintenance

## Operating faults

**Before undertaking any intervention, the installer must carry out the following checks:**

- Is there power to the boiler and burner (light displays on, safety thermostat switched on)?
- Is the oil supply ensured?
- Does the controller or the boiler thermostat indicate heat demand (generate demand)?
- Does the condition of the flue gas system allow for good combustion (date last cleaned)?

Fault	Probable causes	Solution
<b>The burner will not start.</b>	* No power supply.	→ Put the safety thermostat back into operation. → Check fuses and switches. → Increase the set point of the thermostats or controller (adjust to higher than the boiler temperature).
<b>Motor will not start.</b>	* Faulty motor.	→ Replace the motor.
	* Heat protection relay tripped	→ Reset
	* Faulty condenser.	→ Replace the condenser
<b>Mechanical noise.</b>	* Damaged motor bearings. * Fan wheel rubbing.	→ Replace the motor. → Check positioning.
<b>No ignition spark.</b>	* Short circuit in ignition electrodes.	→ Correct ignition electrodes clearance.
	* Ignition electrodes too far apart.	→ Correct ignition electrodes clearance.
	* Dirty, wet electrodes. * Electrodes cable not properly connected.	→ Clean or replace ignition electrodes. → Check connections.
	* Defective ignition electrodes insulation.	→ Replace electrodes.
	* Defective ignition electrodes cable.	→ Replace ignition cable.
	* Defective transformer.	→ Replace transformer.
<b>The control device switches to fault.</b>	* Dirty flame monitor cell.	→ Clean cell.
	* Flame monitor cell adjusted incorrectly * Defective air pressure monitor.	→ Adjust cell → Replace.
	* Flame decreases.	→ Correct burner adjustment.
	* Flame monitor cell or cable defective.	→ Replace cell or cable.
<b>Pump draws no oil.</b>	* Damaged motor-pump coupling.	→ Replace coupling.
	* Unsealed suction filters, piping or pump hood. * Oil inlet/outlet wrong way round.	→ Replace suction filter. → Tighten connections or hood. → Reverse connections.
	* Shutoff valves closed.	→ Open valves.
	* Clogged filter or tank suction filter.	→ Replace filter or suction filter.
<b>Noises in the pump.</b>	* The pump sucks in air.	→ Check suction line seal.
	* Pump runs empty.	→ Clean filter, check suction line if necessary. Check the oil supply line configuration; there must be no constriction or pinching of the tubes, and the heating oil must not be too cold.
<b>Wrong combustion values.</b>	* Wrong adjustment.	→ Check burner adjustment.
	* No air.	→ Correct air flow.
	* Dirty or worn nozzle.	→ Replace nozzle.
	* No atomisation.	→ Connect solenoid valve. → Replace nozzle. → Replace pump.
	* Dirty combustion head	→ Clean combustion head
	* Suction lines dirty.	→ Clean.
	* Insufficiently ventilated boiler room.	→ Improve ventilation.

# Maintenance

## Automatic burner controller displays

Normal burner operation: The code is sent every 5 seconds. In between, the LED is off.

• —	Idle, no heat demand
• — —	Error in power supply (frequency or voltage)
• •	Waiting for oil preheater contact or air pressure monitor opening or air damper position open
• • •	Burner start-up
•	Burner in operation (after safety delay elapsed)
• • — —	Burner switches off
— — — — —	Caution: Machine safe life about to be exceeded

Burner fault: The code is sent every 10 seconds. In between, the LED is permanently on.

— •	Extraneous light
• —	No flame after safety delay elapsed
• • —	Flame failure during operation
— • •	Extraneous light after burner stop
— • • •	Two flame sensors connected
• — — —	Air pressure monitor opens during operation
— — •	Air pressure monitor does not close
• — — —	Air pressure monitor not in idle position
• • — —	Oil preheater temperature not reached
— — • •	Oil preheater temperature shortfall during burner operation
— — — —	Burner manually locked
• • • •	Unknown error code
— — — — —	Machine safe life exceeded
X X X X X X	Device error

Blink signal:

- long (0.5s)
- short (0.1s)
- X undefined

# Circuit diagram

## VB40.420D

A10	Automatic burner controller	T11	Ignition transformer
B1	Flame monitoring	X1	Boiler connection (7-pin)
EV	Remote unlock button	X2	Boiler connection (4-pin)
H1	Burner fault	X3	Water conservation valve connection (3-pin)
KM1	Motor contactor	X4	Separate blower motor power supply (5-pin)
M1	Blower motor	X5	Flame monitor, ignition transformer connection (15-pin)
P1	Elapsed time meter stage 1	X6	Air damper servomotor connection (9-pin)
P2	Elapsed time meter stage 2	X7	Recirculation gap connection (6-pin)
STB	Safety temperature limiter	X8	Remote unlock connection (2-pin)
ST11	Control thermostat (stage 1)	X9	Flame monitor connection (3-pin)
ST12	Control thermostat (stage 2)	Y0	Water conservation valve
SQ1	Air regulation servomotor	Y1	Solenoid valve stage 1
SQ2	Recirculation gap servomotor	Y2	Solenoid valve stage 2

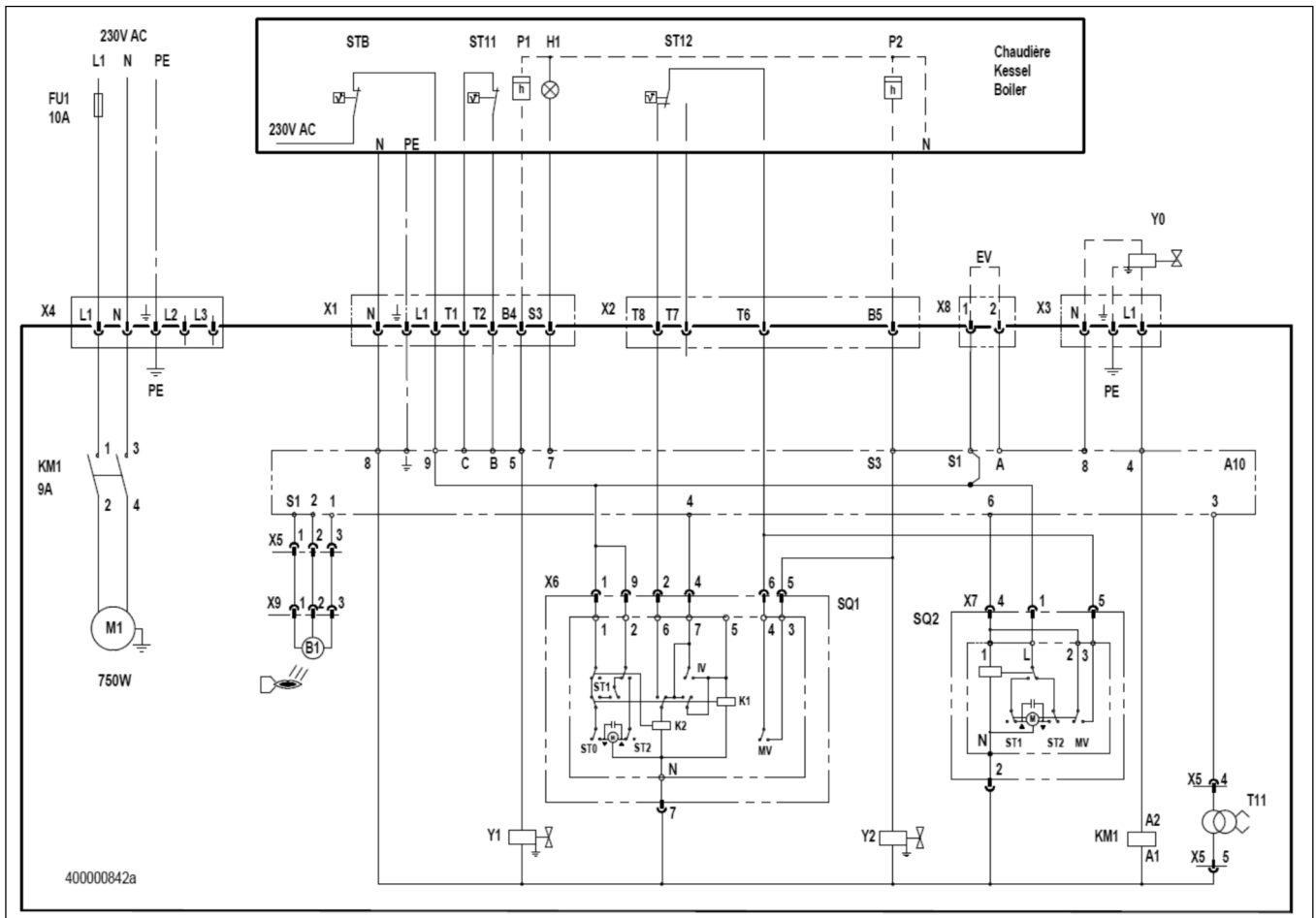

# Circuit diagram

## VB40.460/590D VB45.810D

A10	Automatic burner controller	SQ2	Recirculation gap servomotor
B1	Flame monitoring	T11	Ignition transformer
EV	Remote unlock button	X1	Boiler connection (7-pin)
F1	Thermal relay	X2	Boiler connection (4-pin)
H1	Burner fault	X3	Water conservation valve connection (3-pin)
KM1	Motor contactor	X4	Separate blower motor power supply (5-pin)
M1	Blower motor	X5	Flame monitor, ignition transformer, oil pump motor, oil valves connection (15-pin)
M2	Oil pump motor	X6	Air damper servomotor connection (9-pin)
P1	Elapsed time meter stage 1	X7	Recirculation gap connection (6-pin)
P2	Elapsed time meter stage 2	X8	Remote unlock connection (2-pin)
STB	Safety temperature limiter	X9	Flame monitor connection (3-pin)
ST11	Control thermostat (stage 1)	Y0	Water conservation valve
ST12	Control thermostat (stage 2)	Y1	Solenoid valve stage 1
SP	Air pressure monitor	Y2	Solenoid valve stage 2
SQ1	Air regulation servomotor		

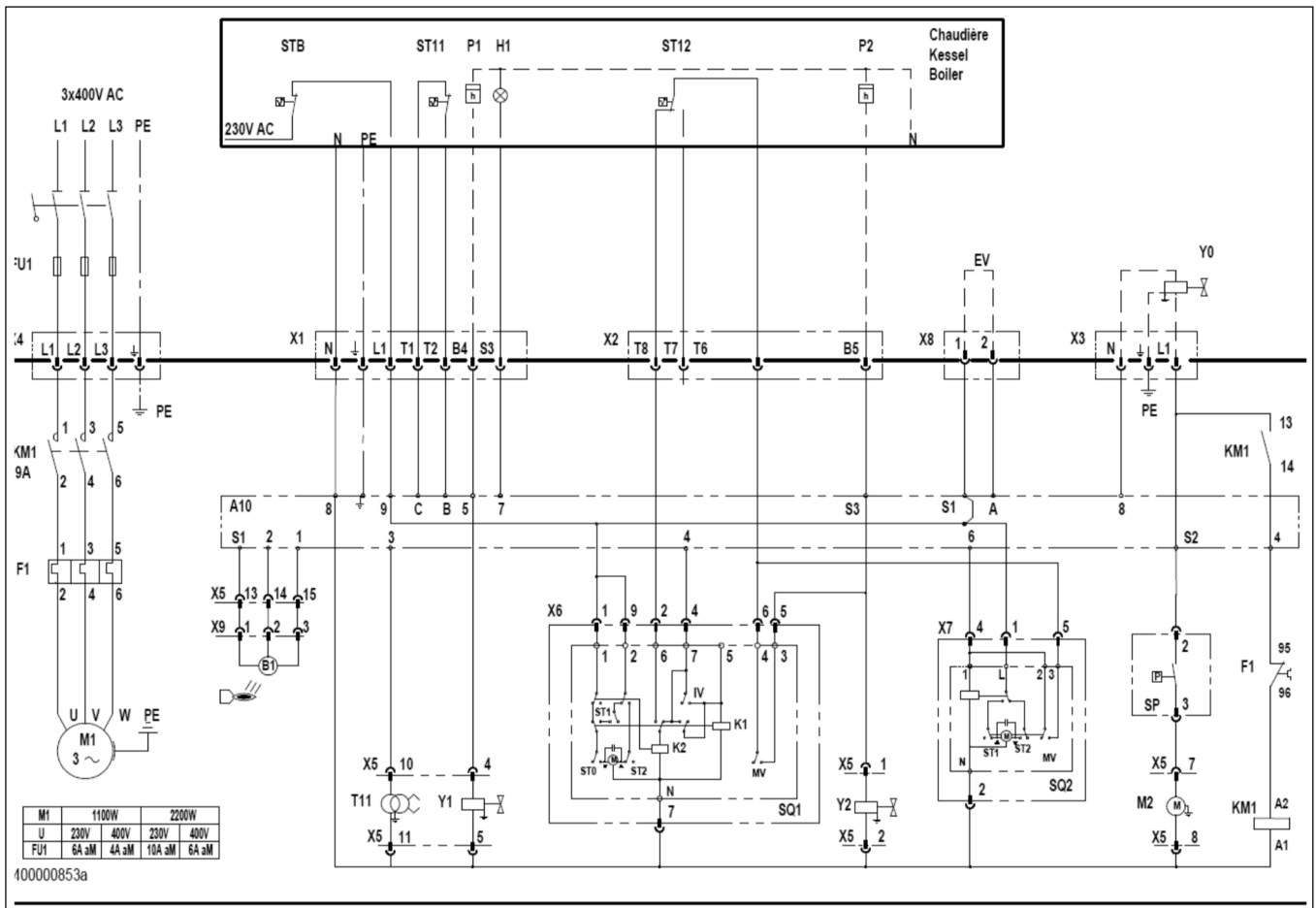

---



# elco

---

**Service:**