



Operating instructions

For specialist installation engineers

Low NOx fuel oil burners 2-25

en

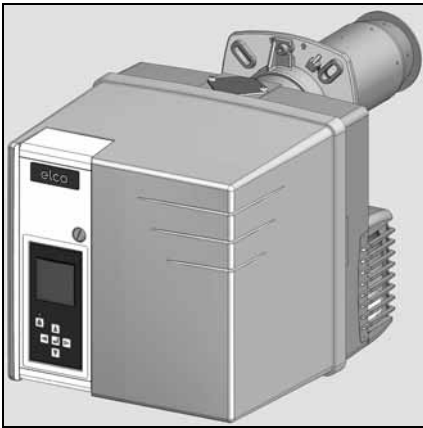

de, fr 4200 1025 2300

it, nl 4200 1025 2400



..... 4200 1025 2200

Overview

Contents

Overview	Contents.....	2
	Important information.....	2
	Burner description.....	3
Operation	Operating mode, safety function.....	4
	Automatic combustion control unit.....	5-7
	Terminal allocation chart, connection socket.....	8-9
	Fuel oil burner pump.....	10
Assembly	Installing the burner, burner installation location.....	11
	Electrical connection, fuel oil connection.....	12
Commissioning	Checks before commissioning.....	13
	Setting data, checking combustion components.....	13
	Air regulation, fuel oil pressure regulation.....	14
	Adjusting burner output.....	15-20
Maintenance	Servicing.....	21-22
	Troubleshooting.....	23
	Fault diagnosis menu.....	24
	Operating statistics menu.....	24-25

Important information

VE 2.100 D and VE 2.150 D Low NOx burners are designed to burn extra light fuel oil in accordance with national standards:

AT: ÖNORM C1109: standard or low sulphur

BE: NBN T52.716: standard or NBN EN590: low sulphur

CH: SN 181160-2: extra-light fuel oil and low sulphur eco fuel oil

DE: DIN 51603-1: standard and low sulphur.

The design and function of the burners meet standard EN 267.

Installation, commissioning and maintenance must only be carried out by authorised specialists and all applicable directives and regulations must be complied with.

Burner description

VE 2.100 D and VE 2.150 D Low NOx burners are two-stage fully automatic monoblock devices. The special design of the combustion head enables combustion with low levels of nitrogen oxide and increased output. Class 3 type-approval in accordance with EN676 certifies that the lowest emission values have been achieved and means that the national environmental regulations have been met

AT: KFA 1995, FAV 1997

CH: LRV 2005

DE: 1.BImSchV

They are suitable for use with all heat generators complying with EN 303 or for use by hot air generators complying with DIN 4794 or DIN 30697 within their respective performance range. Use for any other application requires the approval of ELCO.

Scope of delivery

The burner packaging also contains:

- 1 burner flange with insulation
- 1 bag containing mounting parts
- 1 bag containing Technical Documentation

The following standards should be observed in order to ensure safe, environmentally sound and energy-efficient operation:

EN 226

Connection of fuel oil and forced-draught gas burners to a heat generator

EN 60335-1, -102

Safety of electrical equipment for domestic use

Installation location

The burner must not be used in rooms with aggressive vapours (e.g. hair spray, tetrachloroethylene, carbon tetrachloride), high levels of dust or high air humidity (e.g. laundry rooms).

If no connection to an air exhaust system is provided for the air supply, there must be a supply air inlet measuring:

DE: up to 50 kW: 150 cm²
per additional kW: + 2.0 cm²

CH: QF [kW] x 6= ...cm²; but at least 150 cm².

Variations may arise as a result of local regulations.

Declaration of conformity for fuel oil burners

We, certified company No.AQF030, F-74106 ANNEMASSE Cedex, declare under our sole responsibility that the products
VE 2.100 D
VE 2.150 D

conform to the following standards

EN 50165

EN 55014

EN 60335-1

EN 60335-2-102

EN 60555-2

EN 60555-3

EN 267

Belgian royal decree dated 08/01/2004

These products bear the CE mark in accordance with the stipulations of the following European Directives

89 / 392 /CEE Machinery directive

2004/108/CEE EMC directive

2006 / 95 /CEE Low voltage directive

92 / 42 /CEE EEC Working efficiency directive

Annemasse, 9th March 2010

M. SPONZA

We accept no responsibility for damage arising from:

- inappropriate use.
- incorrect installation and/or repair on the part of the buyer or any third party, including the fitting of non-original parts.

Final delivery and instructions for use

The firing system fitter must supply the operator of the system with operating and maintenance instructions on or before final delivery. These instructions should be displayed in a prominent location at the point of installation of the heat generator. They should include the address and telephone number of the nearest customer service centre.

Notes for the operator

The system should be inspected by a specialist at least once a year. Depending on the type of installation, shorter maintenance intervals may be necessary! It is advisable to take out a maintenance contract to guarantee regular servicing.

Overview

Burner description

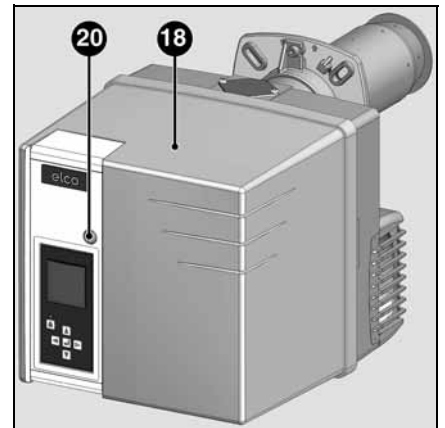
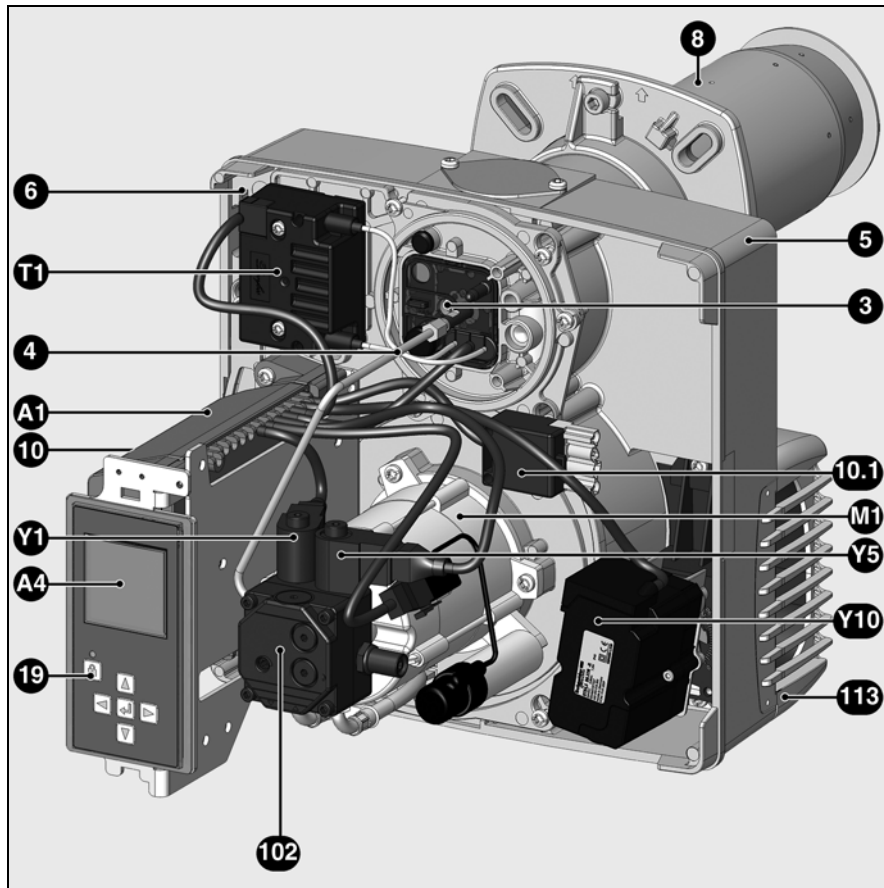

en

- Y10 Air flap servomotor
- A1 Automatic combustion control unit
- A4 Display
- B3 Flame monitor
- M1 Blower and pump motor
- T1 Igniter
- 3 Adjusting screw for dimension Y
- 4 Nozzle line tube
- 5 Housing
- 6 Plate hanging device
- 8 Burner tube
- 10 7-pin connector (hidden)
- 10.1 4-pin connector
- 18 Cover
- 19 Release knob
- 20 Hood securing screw
- 102 Fuel oil pump
- Y1, Y5 Solenoid valves
- 113 Air intake box

Operation

Operation Safety function

Starting the burner

- After heat is requested by the boiler regulator, the automatic combustion control unit starts the program sequence.
- The blower motor starts up, the ignition switches on.
- Pre-ventilation with air flap open (air flap is only closed when the burner is switched off).
- The solenoid valve 6 opens, pressure set by the partial load regulator 5.
- Flame formation.
- Ignition switches off.

Burner operation, regulation between partial load and full load

The burner operates with one nozzle and at two different fuel oil pressures, one for partial load and one for full load. The oil pressures are controlled independently by two pressure regulators in the pump. If an increase in load is requested by the boiler regulator, the burner switches from partial load to full load after a delay of at least 13 seconds.

- Air flap 11 is moved to the full load position by the servomotor.
- When the air flap position is adjustable, the solenoid valve 3 closes, the part-load pressure regulator 5 is deactivated and the full load pressure regulator 2 takes over regulation of the pressure.
- The air flap continues to move to the full load position. The full load is in operation.

Safety function

A safety shutdown is triggered:

- if a flame signal is detected during pre-ventilation (unauthorised flame monitoring),
- if no flame is produced within 5 seconds (safety time) of the burner being started (fuel inlet authorisation),
- if no flame is produced after an unsuccessful restart attempt in the event of flame failure during operation.

A safety shutdown is indicated by the malfunction lamp lighting up. Once the cause of the malfunction has been rectified, it is possible to unlock the control unit by pressing the reset button.

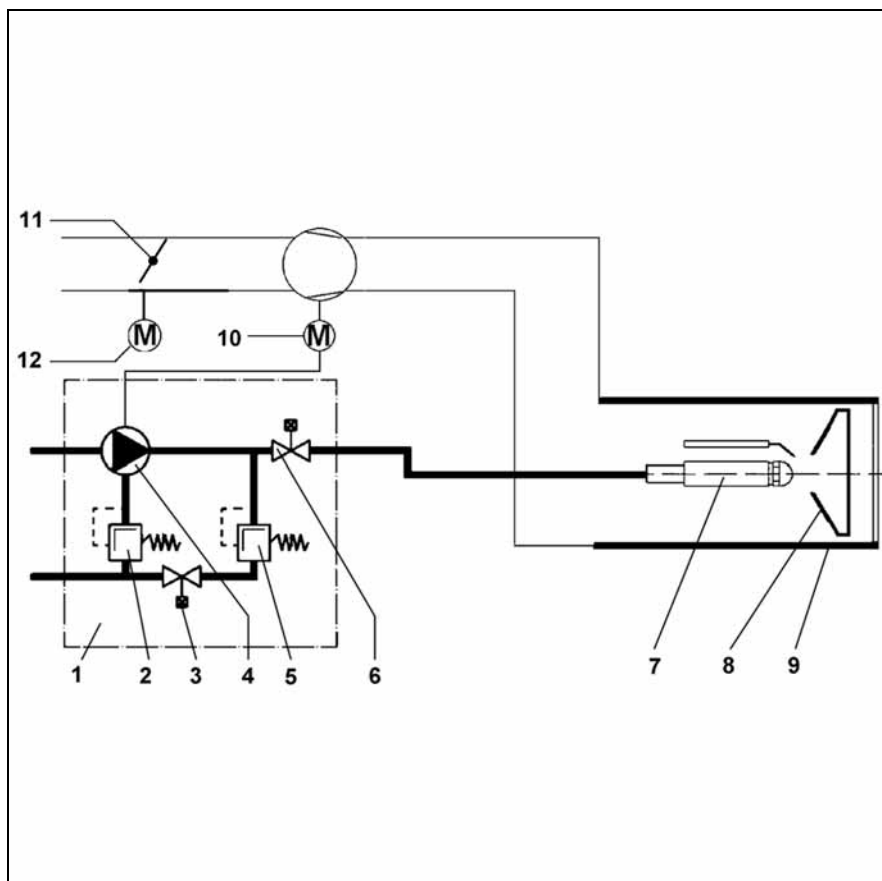

Principle diagram

- 1 two-stage pump.
- 2 Oil pressure regulator, full load
- 3 Solenoid valve, full load (NO)
- 4 Pump
- 5 Oil pressure regulator, partial load
- 6 Solenoid valve (NC)
- 7 Nozzle line
- 8 Baffle plate
- 9 Flame tube
- 10 Burner motor
- 11 Air flap
- 12 Air flap electric servomotor

Operation

TCH 2xx safety unit

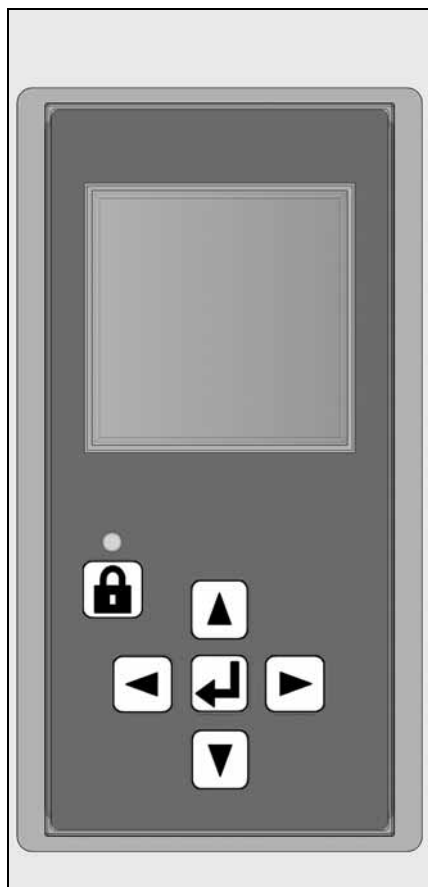

The TCH 2xx fuel oil automatic combustion control unit controls and monitors the forced draught burner. The microprocessor-controlled program sequence ensures maximum stability of time periods, regardless of fluctuations in the power supply voltage or the ambient temperature. The automatic combustion control unit is designed to cope with brownouts. Whenever the supply voltage drops below its rated minimum level (< 185V), the control unit shuts down - even in the absence of a malfunction signal. The control unit switches itself back on again once the voltage has returned to normal levels (> 195V).

Pressing and holding the unlocking button for...	... causes ...
... 1 second ...	the control unit to unlock.
... 2 seconds ...	the control unit to lock.
... 9 seconds ...	the statistics to be deleted

Locking and unlocking

The control unit can be locked using the release knob or unlocked as long as the unit is powered on.

Always switch off the power supply before installing or removing the control unit. Do not attempt to open or carry out repairs on the control unit.

- Moves the cursor upwards.
- Moves the cursor downwards.
- Increases the marked value.
- Modifies/Confirms the value shown.
- Modifies/Confirms the value shown.
- Unlocks the control unit.
- Red LED (flashes if a fault is present).

en

Screen	Description	Screen	Description
	Awaiting the heat request from the boiler		Oil valve is opened, safety time
	Air flap is forced open for pre-ventilation.		Flame stabilises, post-ignition time
	Pre-ventilation and pre-ignition		Flame is present, awaiting authorisation of regulation
	Air flap closes to the ignition position		Burner in operation. The lower cell shows the strength of the signal and the operating time of the burner.

Operation

TCH 2xx safety unit

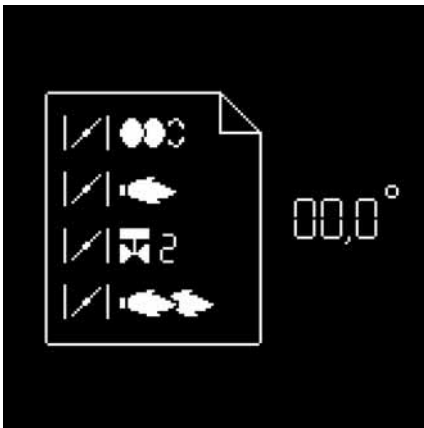

In parallel with its control and safety functions, the TCH2xx control unit allows the following to be set:

- the position of the air flap during ignition
- the position of the air flap during the 1st stage
- the position of the air flap by opening the stage 2 valve (for switching from 1st to 2nd stage)
- the position of the air flap during the 2nd stage
- the position of the air flap by closing the stage 2 valve (for switching from 2nd to 1st stage).

The parameters for the control unit are set using the display and 5 keys. Operating values are shown in real time on the display.

Pressing the keys gives access to 5 menus:
(The last two menus are not activated for VE 2 D burners)

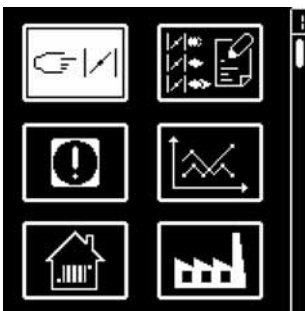

- menu for setting the servomotor,



- menu for storing the servomotor setpoints in the display

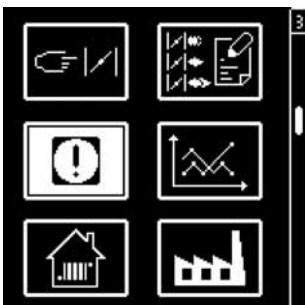

- fault diagnosis menu



- operating statistics menu



- Menu for setting / adjusting the standard configurations. In this menu, it is possible to adjust the control unit's standard configurations. These are pre-set in the factory. No modifications may be carried out on-site without prior consultation with ELCO. The access code and the setting setpoints for this menu are available on request.

Operation

TCH 2xx safety unit

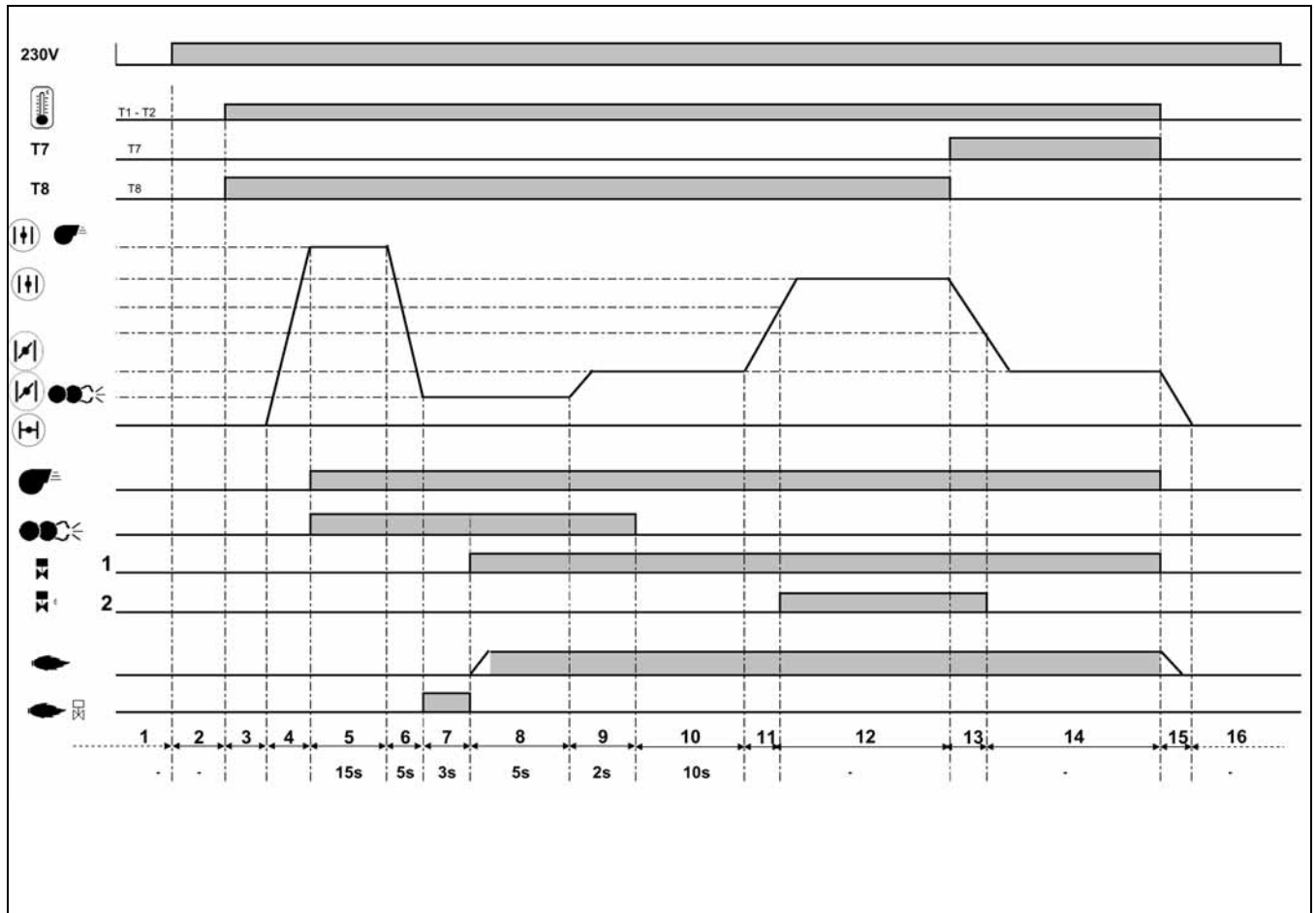

en

Operating cycle phases:

- | | | |
|--|---|---|
| <p>1: No voltage
 2: Powering up, no heat request
 3: Heating request
 4: Air flap opens to the prevention position
 5: Pre-ventilation: Switching on the motor and the igniter
 6: Closing the air flap, switching to the ignition position
 7: Unauthorised flame monitoring</p> | <p>8: Starting the burner: opening the solenoid valve, flame formation, safety time
 9: Flame stabilisation time, post-ignition time
 10: Awaiting regulator release
 11: Opening the air flap, until the opening position of the 2nd stage valve is reached
 12: Operation in 2nd stage
 13: Closing the air flap, until the closing of the 2nd stage valve</p> | <p>14: Operation in 1st stage
 15: Regulator shutdown, closure of the air flap to 0°
 16: Awaiting a new heating request</p> |
|--|---|---|

Operation

Terminal allocation chart 230 Volt connection

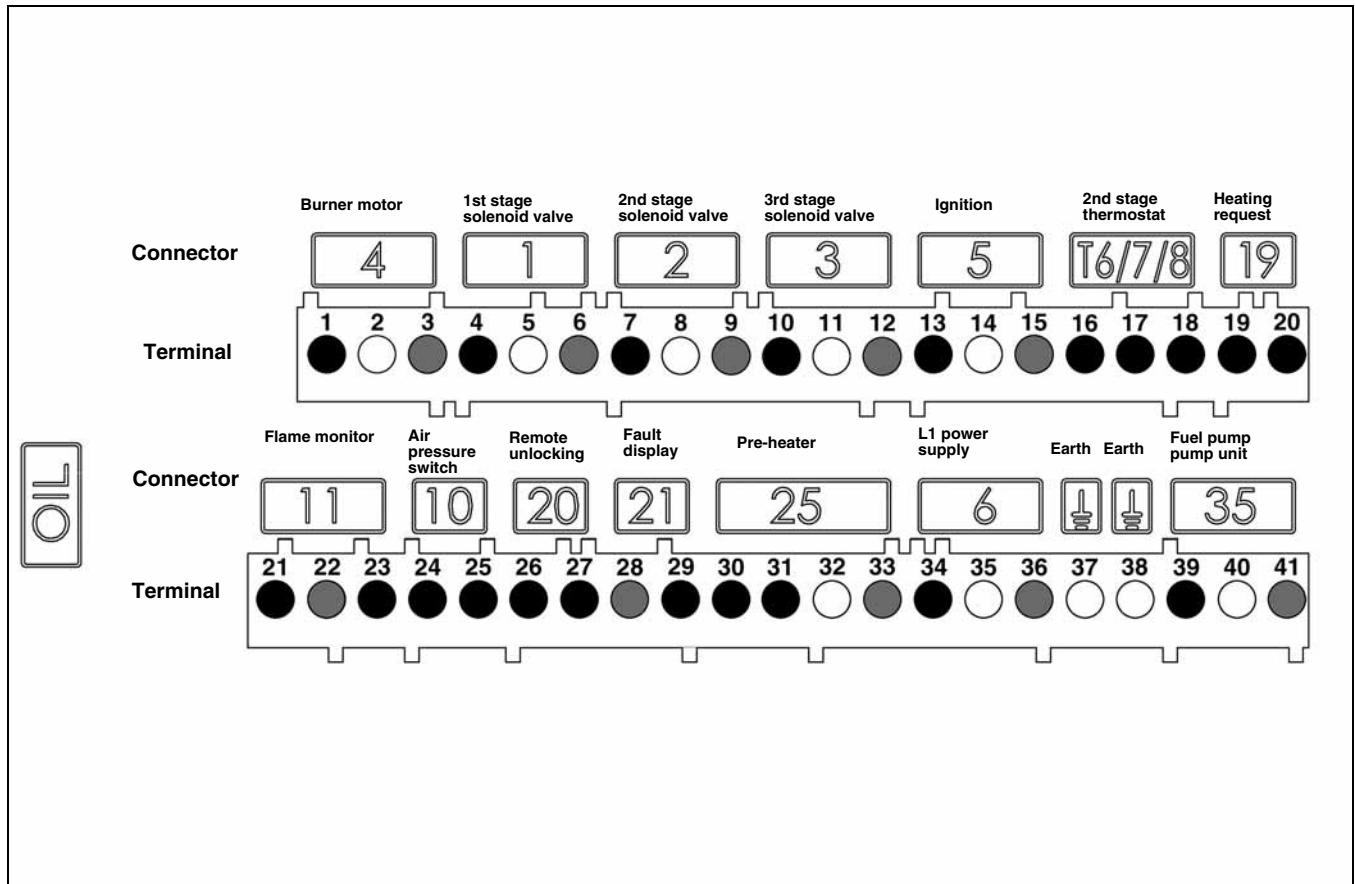

Terminal	Description	Connector	Terminal	Description	Connector
1	Burner motor live	4	21	Flame monitoring signal	11
2	Earth		22	Neutral	
3	Neutral		23	Live	
4	1 st stage solenoid valve live	1	24	Not used	10
5	Earth		25	Not used	
6	Neutral		26	Live	
7	2 nd stage solenoid valve live	2	27	Remote unlocking signal	20
8	Earth		28	Neutral	
9	Neutral		29	Signal fault live	
10	3 rd stage solenoid valve live	3	30	Live	21
11	Earth		31	Preheater/release contact	
12	Neutral		32	Earth	
13	Igniter live	5	33	Neutral	25
14	Earth		34	Live L1	
15	Neutral		35	Earth	
16	2 nd stage thermostat phase (T6)	T6/7/8	36	Neutral	6
17	Signal T7		37	Earth	
18	Signal T8		38	Earth	
19	1 st stage thermostat live (T1)	19	39	Pump unit live	35
20	Heating request signal (option T2)		40	Earth	
			41	Neutral	

Operation

Terminal allocation chart Low voltage connections

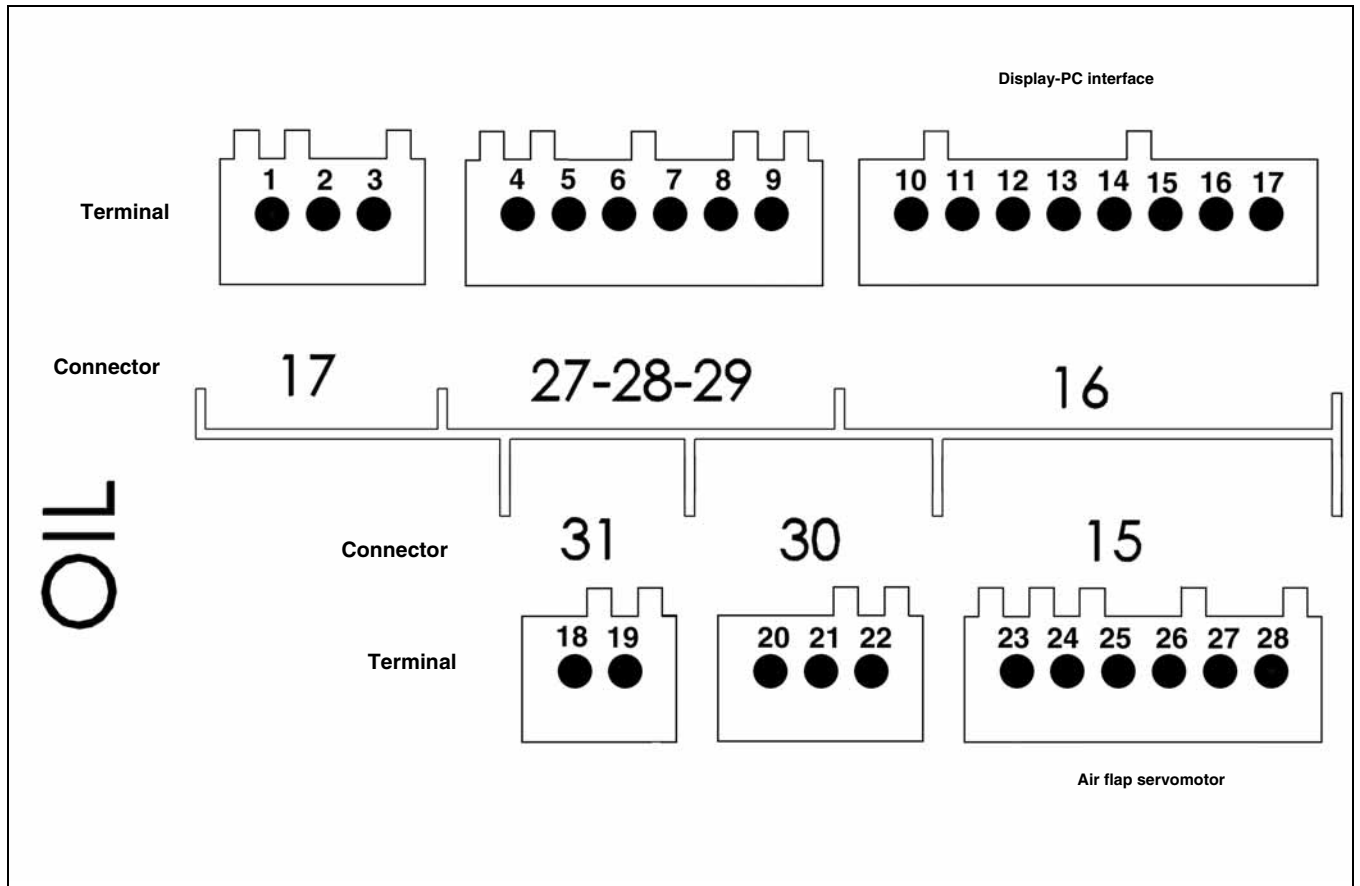

en

Terminal	Description	Connector	Terminal	Description	Connector
1	Not used	17	18	Not used	31
2	Not used		19	Not used	
3	Not used		20	Not used	
4	Not used	27 28 29	21	Not used	30
5	Not used		22	Not used	
6	Not used		23	Air flap servomotor	
7	Not used		24		
8	Not used		25		
9	Not used		26		
10	Display-PC interface	16	27		
11			28		
12					
13					
14					
15					
16					
17					

Operation

Pump

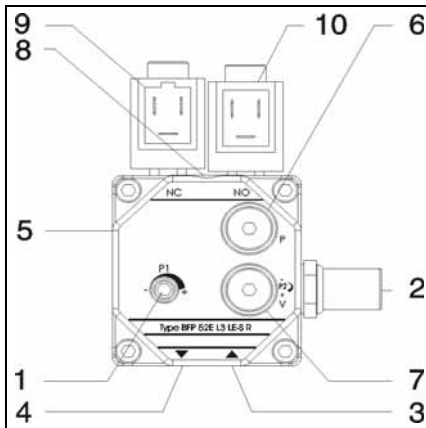

The pump is a gear pump. It must be connected as a two-line pump via a bleed filter. For the connection of the fuel oil tank and the bleed filter, it is better to use the single line option. An intake filter and two oil pressure regulators are integrated in the pump. Pressure gauges for pressure measurements **6** and negative pressure measurements **7** must be connected before the equipment is commissioned.

- | | | |
|----|-------------------------------|-------|
| 1 | Pressure setting, 1st stage | |
| 2 | Pressure setting, 2nd stage | |
| 3 | Vacuum connection | G 1/4 |
| 4 | Return connection | G 1/4 |
| 5 | Nozzle supply line connection | G1/8 |
| 6 | Pressure gauge connection | |
| 7 | Vacuum gauge connection | |
| 8 | Filter | |
| 9 | Solenoid valve, 1st stage | |
| 10 | Solenoid valve, 2nd stage | |

Assembly

Burner assembly

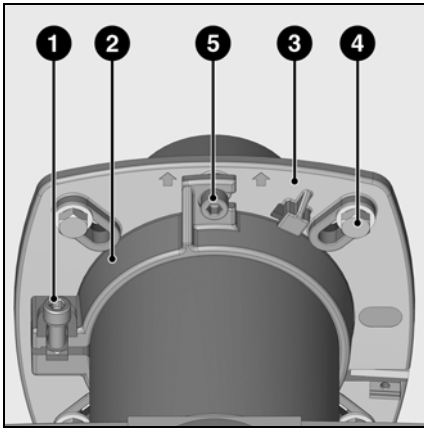

Burner assembly

Burner flange **3** is equipped with elongated holes and can be used with a hole circle diameter of 150 - 184mm. These dimensions comply with EN 226. Sliding pipe bracket **2** on the burner pipe makes it possible to adjust the installed depth of the mixing unit to the geometry of the combustion chamber concerned. The installed depth remains the same during fitting and removal. Pipe bracket **2** secures the burner to the connecting flange and therefore to the boiler. This completely seals off the combustion chamber.

Installation:

- Secure connecting flange **3** to the boiler using screws **4**
- Fit pipe bracket **2** to the burner pipe and secure using screw **1**. Tighten screw **1** to a maximum torque of 6 Nm.
- Turn the burner slightly, guide it into the flange and secure using screw **5**.

Removal:

- Loosen screw **5**
- Turn the burner out of the bayonet socket and pull it out of the flange.

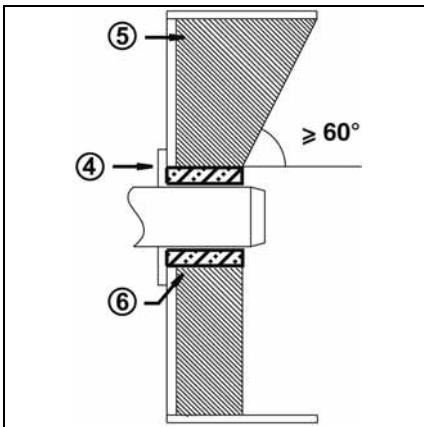

Burner tube installation depth and brickwork surround

Unless otherwise specified by the boiler manufacturer, heat generators without a cooled front wall require brickwork or insulation **5** as shown in the illustration opposite. The brickwork must not protrude beyond the leading edge of the flame tube, and should have a maximum conical angle of 60° . Space **6** must be filled with an elastic, non-flammable insulation material.

 For assembly in the position with the volute facing upwards, unclip the display from its support, turn it over 180° , and refit it.

Exhaust gas evacuation system

To avoid unpleasant noise emissions, right-angled connectors should not be used on the flue gas side of the boiler.

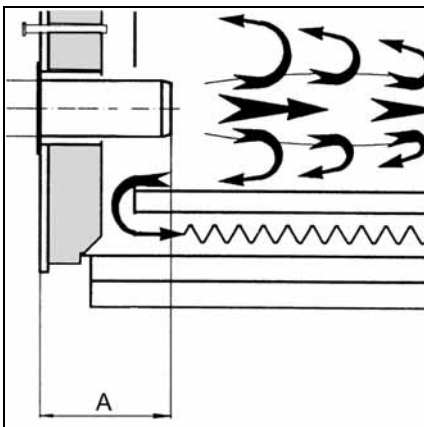

On boilers with reverse firing, minimum flame tube insertion depth **A** should be observed as per the boiler manufacturer's instructions.

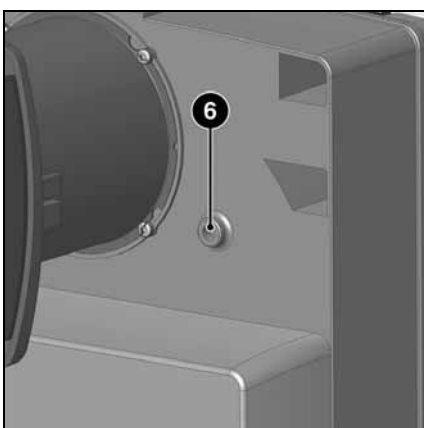

Inspection glass cooling

The burner housing can be equipped with an R1/8" connection to support a line for cooling the inspection glass of the boiler.

- To do this, drill through boss **6** and cut an 1/8" thread.

Use accessories article No. 12 056 459 for the connecting nipple and connection hose.

en

Assembly

Electrical connection Fuel oil connection

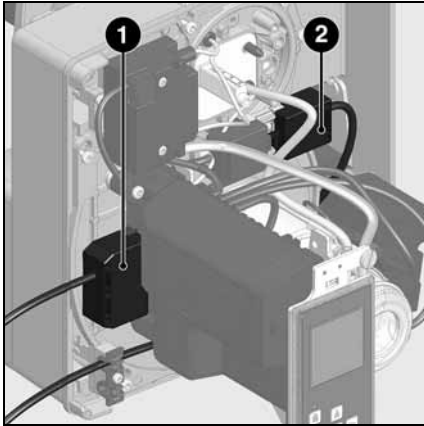

Electrical installation and connection work must only be carried out by a suitably qualified electrician. All applicable regulations and directives must be observed.

Electrical connection

- Check to ensure that the power supply is as specified (230V, 50 Hz single phase with neutral and earth)
Boiler fuse: 10 A

Electrical connection



It must be possible to disconnect the burner from the mains using an omnipolar shutdown device complying with the standards in force. The burner and heat generator (boiler) are connected by a 7-pin Wieland connector **1** and a 4-pin Wieland connector **2** (**not supplied**). The diameter of the cables connected to these connectors must be between 8.3 and 11 mm.

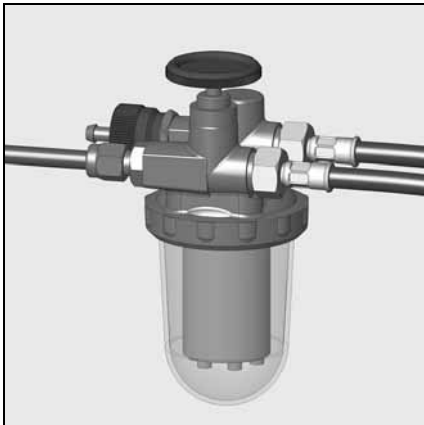

Fuel oil connection

The fuel oil connection must be done via a bleed filter. The filter must be positioned in such a way as to ensure the hoses are routed correctly. The hoses must not be pinched. The fuel oil pipes used must be in DN6 or DN8 copper pipe.

CH: Fuel oil pipe in
DIN 16773 polyamide.

For the maximum values of the suction lengths and heights, see the directive for carrying out and sizing installations with suction.

This directive forms an integral part of the elements ELCO planning is based

on. The suction strainer must not be less than 5cm from the bottom of a square tank and not less than 10cm from the bottom of a cylindrical tank.

Fuel oil connection

To ensure the operating safety of the system, the fuel oil supply must be installed carefully in compliance with local regulations.

Important:

- Maximum pressure at the pump intake < 1.5 bar.
- Maximum vacuum pressure at the pump < 0.4 bar.
- Before commissioning, fill the oil lines and check there are no leaks.

Commissioning

Checks before commissioning Adjustment data Checking combustion components

Checks before commissioning

The following must be checked before initial commissioning:

- That the burner is assembled in accordance with the instructions given here.
- That the burner is pre-set in accordance with the values in the adjustment table.
- Setting the combustion components.
- The heat generator must be ready for operation, and the operating regulations for the heat generator must be observed.
- All electrical connections must be correct.
- The heat generator and heating

system must be filled with water and the circulating pumps must be in operation.

- The temperature regulator, pressure regulator, low water detectors and any other safety or limiting devices that might be fitted must be connected and operational.
- The exhaust gas duct must be unobstructed and the secondary air system, if available, must be operational.
- An adequate supply of fresh air must be guaranteed.
- The heat request must be available.
- Fuel storage tanks must be full.

- The fuel supply lines must be assembled correctly, checked for leaks and bled.
- A standard-compliant measuring point must be available, the exhaust gas duct up to the measuring point must be free of leaks to prevent anomalies in the measurement results.

en

Burner	Burner power kW		Fuel-oil flow kg/h		Nozzle 45°H Gph (Danfoss)	Pump pressure bar		Dimension Y mm	Air flap position in °			
	1. stage	2. stage	1. stage	2. stage		1. stage	2. stage		Ignition	1. stage	Stage changeover	2. stage
VE2.100 D	50	62	4,0	5,3	1,0	12	19	5	2	2	0	30
	60	82	5,0	6,9	1,25	11	22	10	10	10	35	60
	75	97	6,4	8,2	1,65	11	18	12	30	30	0	90
VE2.150 D	60	76	4,8	6,4	1,20	12	19	7	4	4	0	30
	89	120	7,5	10,1	2,00	11	22	15	20	20	35	70
	105	145	8,9	12,3	2,50	10	18	20	35	35	0	90

Bold : Delivery setting; 1kg fuel-oil at 10°C = 11.86kWh

The settings data below are **basic settings**. The factory settings data is highlighted in bold and with a grey background. With a normal case, these settings enable the commissioning of the burner. In all cases, carefully check the settings values. In most cases, according to the installation, corrections must be made.

Checking checking combustion components

- Remove the cable connector from cell **B3** on the unit.
- Loosen the three cover screws **W**.
- Remove the mixing unit.

- Undo clamping screw **S** on the air metering tube and move it to the rear.
- Check nozzle sizes and exchange in accordance with the parts specified in the above table if necessary.
- Check the adjustment of the ignition electrodes block and the baffle plate and adjust if necessary.
- Check the gap between nozzle and baffle plate and adjust if necessary.
- Push the tube forwards and secure it using clamping screw **S**. Warning: the flame monitor must be positioned opposite the ignition electrodes, i.e. underneath the nozzle.

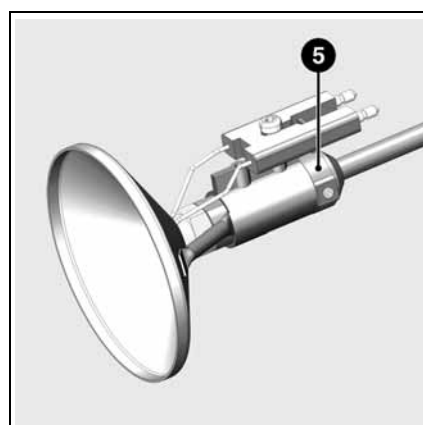
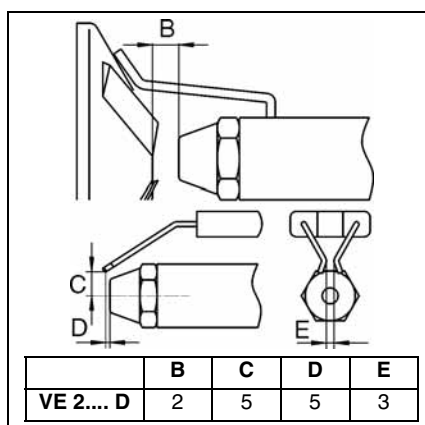
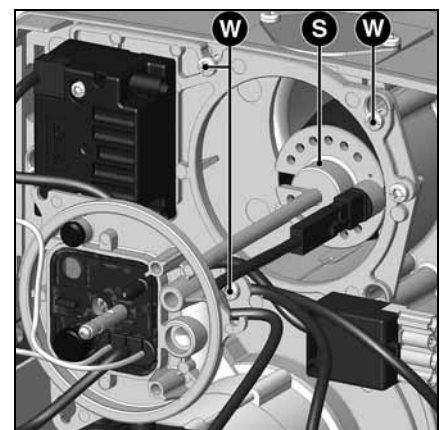

Combustion head settings

Head setting values (space between nozzle and turbulator - dimension **B**, space between nozzle and ignition electrodes - dimension **C**) can be checked with enclosed drawing. The two dimensions are set in the factory. Dimension **B** was set thanks to adjust ring **5**. While reassembling the turbulator for a nozzle replacement, it is not necessary to re-adjust dimension **B**, as far as the turbulator is re-assembled on the stop on ring **5**.

Commissioning

Air regulation Fuel oil pressure regulation

Air regulation

Combustion air is regulated at two points:

- on the pressure side, by the gap between the baffle plate and the burner tube.
- on the vacuum side, by the air flap driven by servomotor **Y10**.

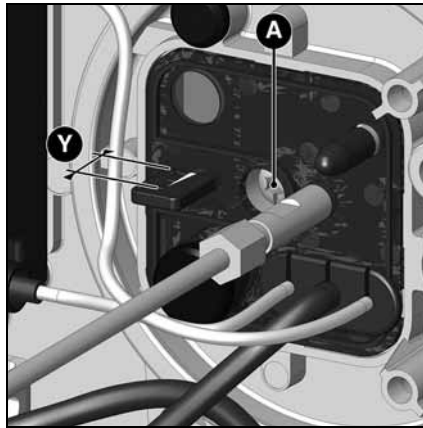

The regulation of air in the burner head affects not only the air flow but also the mixing zone and the air pressure in the burner tube. Rotation of setting screw **A**

- right: more air
- left: less air

- Adjust dimension **Y** in accordance with the settings table.

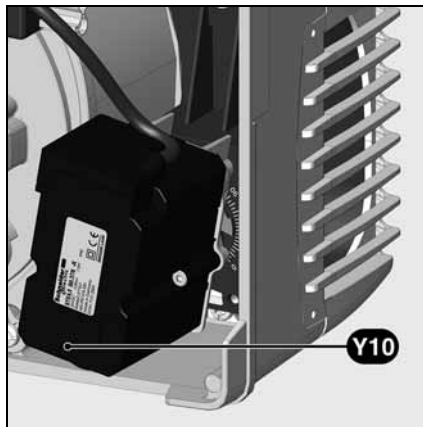

Air regulation by air flap

Air is regulated on the vacuum side by an air flap. This is driven by servomotor **Y10**.

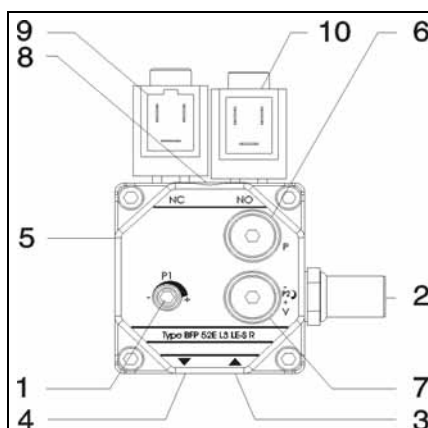

- | | | |
|----|-------------------------------|-------|
| 1 | Pressure setting, 1st stage | |
| 2 | Pressure setting, 2nd stage | |
| 3 | Vacuum connection | G 1/4 |
| 4 | Return connection | G 1/4 |
| 5 | Nozzle supply line connection | |
| 6 | Pressure gauge connection | G1/8 |
| 7 | Vacuum gauge connection | |
| 8 | Filter | |
| 9 | Solenoid valve, 1st stage | |
| 10 | Solenoid valve, 2nd stage | |

Fuel oil pressure regulation

The fuel oil pressure is adjusted using fuel oil pressure regulator **1** for the 1st stage and fuel oil pressure regulator **2** for the 2nd stage. To check the pressure, connect a R1/8" pressure gauge to connector **6**.

Turn

- right: to increase the pressure
- left: to reduce the pressure

Checking the vacuum pressure

The vacuum meter for checking negative pressure must be connected to point **7**, R1/8". Maximum authorised vacuum: 0,4 bar. At higher vacuum pressures, the fuel oil gasifies, which causes scraping noises in the pump and risks damaging it.

Commissioning

Pre-setting without flame

Setting is carried out in 2 phases:

- pre-adjustment without flame
- setting the flame, to fine tune the settings based on the combustion results

When the burner is switched on, the control unit displays the screen below.

Important

At this point, no setting position for the servomotor has been defined, therefore the burner cannot be started under these conditions.

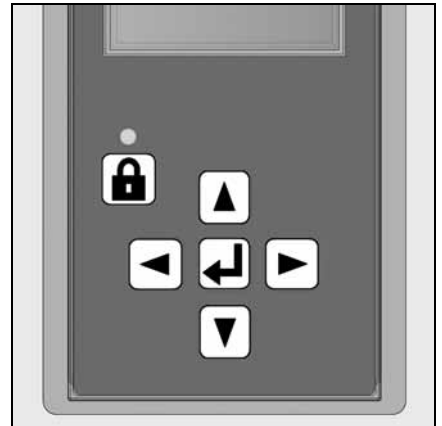

en

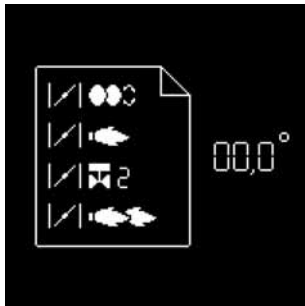

- Press any button and the following screen will appear:



The overall view of the menus is displayed, and the air flap positions settings menu is selected.

- Open the settings menu by pressing the button

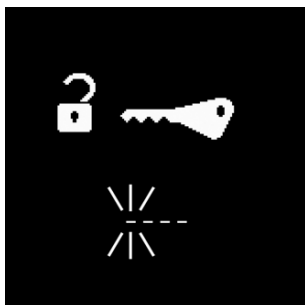

You must now enter the access code (see the label on the back of the display)

- Increase or decrease the value in increments by repeatedly pressing or .
- When the first figure has been set, move the cursor to the right by pressing .
- Repeat the operation until you reach the last figure.
- Confirm the access code by pressing .

The control unit then opens the settings mode. The screen displays the factory pre-settings for the different positions of the air flap (here for example: for a VE 2.150 D).

The following positions for the air flap are presented:



- ignition position (when the menu is opened, the cursor goes to this position)
- position of the air flap during the 1st stage
- position of the air flap when the 2nd stage fuel oil valve is opened
- position of the air flap during the 2nd stage



Modifying a settings value for the servomotor position:

- To modify the value of a position, move the cursor to the corresponding location with the button or .
- Select the value to be modified using the button , the selected value will flash.
- Increase or decrease the value in increments of 0.1° by repeatedly pressing or . For large modifications, press and hold the or button, the value will scroll quickly up or down.
- Confirm the new value using the button . The value stops flashing.

N.B.:



It is possible to set different positions within a large range of values. However, for safety reasons, the control unit enforces a minimum interval of 2° between the different positions (except between the ignition position and the 1st stage).



Commissioning

Pre-setting without flame General advice before starting the burner

End of settings menu without flame

When all the positions of the servomotor have been determined according to the required settings, it is then possible to move on to the next section for commissioning - "Setting the flame".

To do this, place the cursor in the lower part of the screen on the symbol  and confirm by pressing the button .

If it is necessary to quit the menu without saving the pre-settings, position the cursor on the symbol  and confirm with the button .

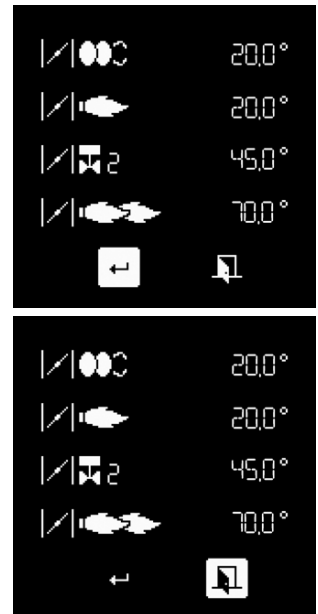

Preparing the burner start-up

Before starting the burner, draw fuel oil in using a hand pump until the filter is completely filled. Then start the burner by switching on the boiler regulator. Open the bleed screw on the oil filter to allow the oil line to bleed fully during the pre-ventilation phase. The negative pressure must not fall below 0.4 bar. Close the bleed screw when the filter is completely filled with fuel oil and fuel oil is flowing out without bubbles.

Optimising combustion values

Optimum combustion values can be achieved by adjusting the position of the baffle plate (dimension **Y**) if necessary. Doing this can have an effect on starting characteristics, pulsation and combustion values. Any reduction in dimension **Y** increases the CO₂ value. However, starting characteristics become harsher. Compensate for the change in airflow if necessary by adjusting the air flap position.

Precautions: To avoid condensation, observe the minimum required flue gas temperature specified by the boiler manufacturer and comply with the requirements for flue gas ducts.

If dimension **Y** needs to be corrected again when the 2nd stage is adjusted, it will be necessary to check the adjustment values for the 1st stage.



Risk of air blast!
Continuously check CO, CO₂ and soot emissions when adjusting. Optimise combustion values if CO is present. The CO level must not exceed 50 ppm.

Function check

Flame monitoring must be checked for safety as part of initial commissioning and also after servicing or if the system has been out of operation for any significant period of time.

- Start attempt with the flame detection cell obscured:
at the end of the safety time, the control unit must switch to malfunction mode!
- Start-up with the flame detection cell lit up: the automatic combustion control unit must switch to malfunction mode after 10 seconds of pre-ventilation.
- Normal start; if the burner is in operation, cover the flame detection cell: the automatic combustion control unit must switch to malfunction mode after a restart and the end of the safety time

Commissioning

Setting the flame



- **If the boiler heating request is not present**, the boiler remains on standby. In this case, it is still possible to return to the previous setting menu "Pre-setting without flame". To do this, position the cursor on the symbol and confirm with the button .

The air flap switches to the ignition position.



en

The fuel valve opens.
Awaiting flame signal

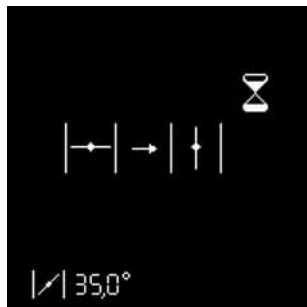

- **If a boiler heating request is present** (T1-T2 contact closed), the burner starts. The air flap is opened to move to the pre-ventilation position.

If no flame is detected at the end of the safety time, the control unit switches to malfunction mode.



Flame detected
Flame stabilisation



Pre-ventilation and pre-ignition

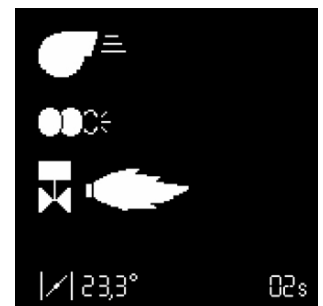

The control unit awaits the regulation authorisation.



Setting the flame



Setting the 1st stage

If the flame has been detected and stabilised, the control unit sets the burner to the 1st stage as soon as it receives the regulation authorisation.

- Adjust the fuel oil pressure for the 1st stage depending on the required output, using the regulator **8** on the pump. Monitor the combustion values continuously as you do so (CO, CO₂, soot test). If necessary, adjust the dimension **Y** and/or adapt the airflow.



To do this, modify the position of the servomotor in 1st stage. Proceed as described on page 15, in the paragraph "**Modifying the value of a servomotor position setting**"

- Precautions: when modifying the setting value, the servomotor will move in real time. As a consequence, the combustion values must be constantly checked.



Specific function: ignition checking

If the ignition position has been modified, it is possible to carry out a new burner start-up to check the new ignition position, without having to quit the settings menu.

To do this, after modifying the ignition position, position the cursor on the symbol , and initiate the new start-up using the button .



Setting the opening position of the 2nd stage fuel oil valve

After the 1st stage is set, it is possible to set the opening value for the **2nd stage** fuel oil valve. Proceed as described in the paragraph "**Modifying the value of a servomotor position setting**"

- Precautions: in this case the servomotor does not move immediately, but first remains in the 1st stage position (the actual position of the servomotor is always displayed in the lower part of the display). The 2nd stage valve also remains closed. Firstly it is possible to modify the position of the 2nd stage air flap.



Setting the 2nd stage

To set the position of the air flap in the 2nd stage, position the cursor on the corresponding line on the display using the button . If necessary, modify the setting value. Proceed as described in the paragraph "**Modifying the value of a servomotor position setting**".

- To make the burner actually switch to the 2nd stage, press the button  again. The servomotor will then move the air flap to the set position. At the same time, the 2nd stage fuel oil valve will open, as soon as the opening position set for the servomotor is passed.
- Adjust the fuel oil pressure for the 2nd stage depending on the required output, using the regulator **9** on the pump. Monitor the combustion values continuously as you do so (CO, CO₂, soot test). If necessary, adjust the dimension **Y** and/or adapt the airflow.





To do this, modify the position of the servomotor in the 2nd stage. Proceed as described on page 15, in the paragraph "**Modifying the value of a servomotor position setting**"

- Precautions: when modifying the setting value, the servomotor will move in real time. As a consequence, the combustion values must be constantly checked.



Specific function: position the opening and closing of the 2nd stage fuel oil valve differently

The control unit has the possibility of setting the opening of the 2nd stage valve, when the 1st stage changes to the 2nd stage, at a different position to that for closing when the 2nd stage drops to the 1st stage.

- To do this, as described before, first set the opening position of the 2nd stage fuel oil valve.
- Lastly position the cursor on the symbol  and confirm with the button . The selected symbol will change like this one .
- Using the button , position the cursor on the setting value of the 2nd stage fuel oil valve, and fix the new closure position, as described in the paragraph "**Modifying the value of a servomotor position setting**".

Commissioning

Setting the flame Operating mode

en



Closing the "Setting the flame" menu

The burner setting is now complete. If necessary, it is possible to again correct each of the settings values. To do this, position the cursor on the value to be modified, using the button or .

Otherwise, at all times, the following possible ways of closing the "Setting the flame" menu are available:

- Returning to the burner settings with passing through the pre-setting phase (without entering a password). To do this, position the cursor on the symbol and confirm with the button . All the settings values already saved therefore remain available.



- Saving the fixed values and ending the setting procedure. To do this, position the cursor on the symbol and confirm with the button . The burner is then ready to operate and can now be controlled by the boiler regulation.



- Quitting the settings menu without reaching the end of the setting procedure. To do this, position the cursor on the symbol and confirm with the button . All the servomotor positions saved up to this point are recovered by calling up the settings menu again.



Operating mode - Display of the operating status, the flame signal and the operating time

After having completed the setting of the burner, it switches to operating mode.

The current operation of the burner (Operation in 1st or 2nd stage) is indicated by the light bar.

The lower cell shows the intensity of the signal. The display range is from 0 μA to 13 μA . A good quality signal is above 3 μA .

The following limit values are valid:

- When checking an unwanted flame: the signal must be $< 0.7\mu\text{A}$
- During the safety time: the signal must be $> 1.3\mu\text{A}$
- During operation: the signal must be $> 1.1\mu\text{A}$

The cell at the bottom right displays the current operating time of the burner.



Commissioning

Saving the adjustment values in the display





Saving the adjustment values in the display

If the burner setting procedure has been successfully completed, the servomotor positions for all the operating states will be fixed in the control unit. It is possible to store a backup copy of the values in the display.

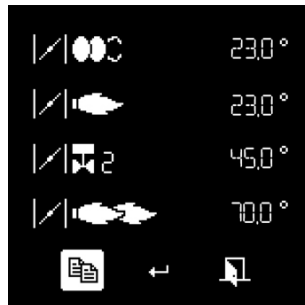

To do this, press the button , the screen opposite is displayed. Using the button  select the menu "Save adjustment values" and confirm with the button .

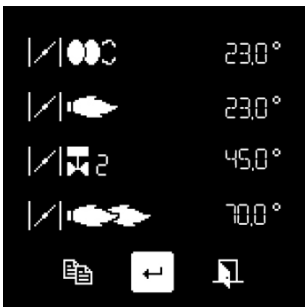

The screen opposite appears. Place the cursor on the symbol , press the button  to begin loading the adjustment values from the control unit to the display.



At this point, it is possible to:

- store the values in the display; to do this place the cursor on the symbol  and confirm with button .
- quit the menu without storing the data, with the symbol .

Maintenance

Servicing

Burner and boiler servicing must only be carried out by a professional heating engineer trained in these operations. The system operator is advised to take out a maintenance contract to guarantee regular servicing. Depending on the type of installation, shorter maintenance intervals may be necessary.



- Switch off the power supply before all maintenance and cleaning work.
- Use original spare parts.

Work recommended as part of annual burner maintenance:

- Burner test run, input measurement in the boiler room
- Clean the combustion components and replace defective parts if necessary
- Cleaning the fan wheel and blower and checking the pump coupling
- Check the nozzle; replace if necessary
- Checking or replacing the fuel oil filters (pump, feed lines)
- Visual inspection of the fuel oil hoses; replace if necessary
- Visual inspection of the burner's electrical components; elimination of damage if necessary

- Check burner start characteristics
- Checking oil pressure and vacuum at the burner pump with the burner in operation
- Flame detector and control unit function check
- Correct the adjustment values if necessary
- Draw up a measurement report

General checks

- Emergency stop button function check
- Visual inspection of oil lines in the boiler room

en

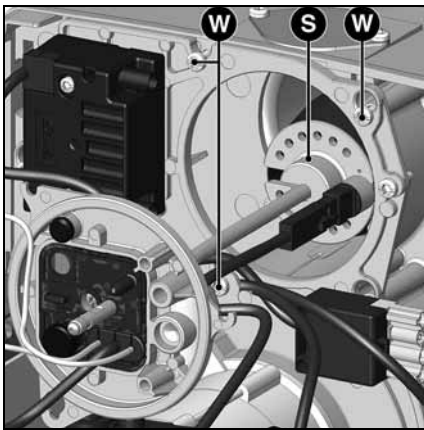

Checking combustion components

- Remove the cable connector from cell **B3** on the unit.
- Loosen the three cover screws **W**.
- Remove the mixing unit.
- Undo clamping screw **S** on the air metering tube and move it to the rear.
- Check nozzle size and exchange in accordance with the parts specified in the table page 13 if necessary.
- Check the adjustment of the ignition electrodes block and the baffle plate and adjust if necessary.
- Check the gap between nozzle and baffle plate and adjust if necessary.
- Push the tube forwards and secure it

using clamping screw **S**. Warning: the flame monitor must be positioned opposite the ignition electrodes, i.e. underneath the nozzle.

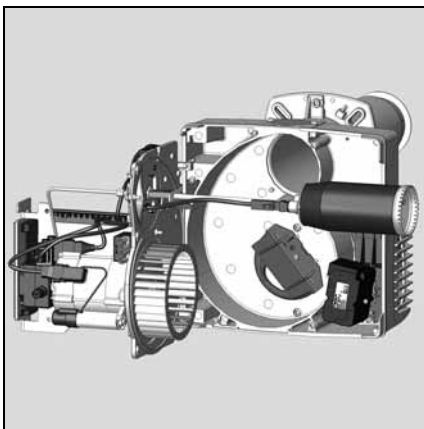

Cleaning the fan wheel

- Remove the equipment plate and attach it in the service position (see illustration).
- Remove and clean the fan wheel and replace it if necessary. Reassemble in the reverse order.

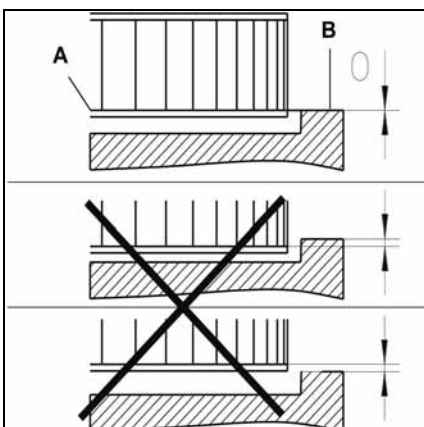

Fitting the fan wheel

When changing the motor or the fan wheel, refer to the positioning diagram opposite. The internal flange **A** of the fan wheel must be aligned with plate **B**. Insert a ruler between the vanes of the fan wheel and bring **A** and **B** to the same height. Tighten the cone-point screw on the fan wheel.

Servicing

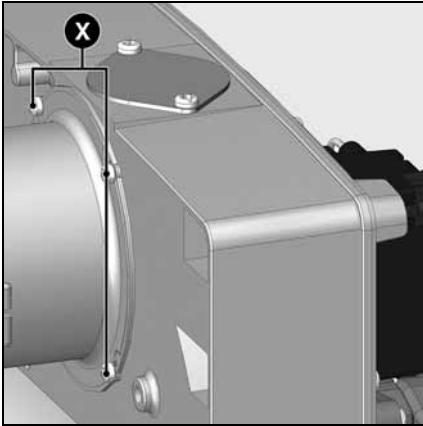

Replacing the flame tube

It is necessary to remove the burner for this work.

- Loosen the clamping screw on the connecting flange.
- Turn the burner out of the bayonet socket, lift it slightly and pull it out of the connecting flange.
- Place the burner on the floor.
- Loosen the 4 screws X on flame tube.
- Pull the flame tube out towards you.
- Fit and secure the flame tube.



The flame tube may be very hot

Filter replacement

The filter element of the multiblock must be checked at least once a year and replaced if clogged.

- Loosen the screws of the filter cap on the multiblock.
- Remove the filter element and clean its housing.
- Do not use any pressurised cleaning products.
- Replace the filter element with a new element.
- Screw the cover back into place.
- Reopen the manual shut-off valve.
- Check it is airtight.
- Check the combustion values.

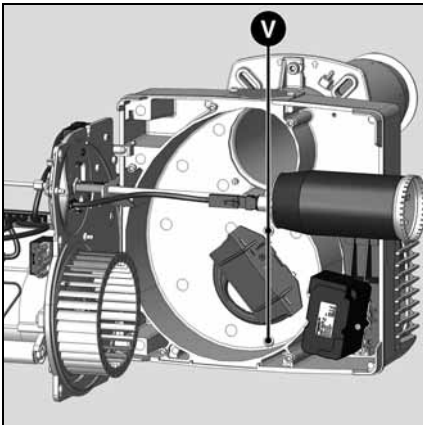

Cleaning the air intake box

- Unscrew securing screws V on the air intake box.
- Remove and clean the air intake box. Reassemble in the reverse order.
- Note the correct position of the air flap and the servomotor.

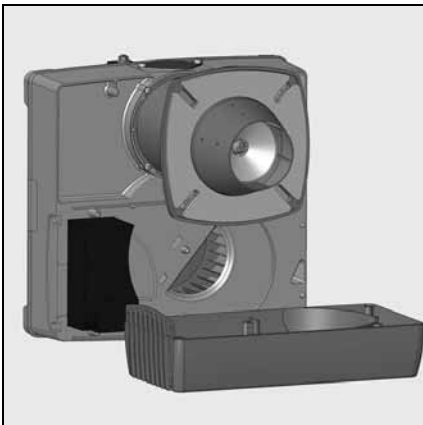

Cleaning the cover

- Do not use abrasive products or products containing chlorine.
- Clean the cover with water and a suitable cleaning product.
- Refit the cover.



Precautions

After any operation: check the combustion performance under real operating conditions (doors shut, cover fitted etc.). Record the results in the relevant documents.

Checking the flue gas temperature

- Check the flue gas temperature at regular intervals.
- Clean the boiler if the flue gas temperature is more than 30 °C above the value measured at the time of commissioning.
- Use a flue gas temperature gauge to make the check easier.

Troubleshooting

Malfunction diagnosis and repair

In the event of a malfunction, first check that the prerequisites for correct operation are fulfilled:

1. Is there any current?
2. Is there fuel oil in the tank?
3. Are all shut-off valves open?
4. Are all control and safety devices, such as the boiler thermostat, low-water detector, limit switch, etc. correctly set?

If the cause of the malfunction cannot be ruled out by the checks described above, check the functions of the various burner components.







Important safety components must not be repaired; these components must be replaced by parts with the same part number.

⚠ Only use original spare parts. Switch off the power supply before carrying out maintenance or cleaning.

After any operation: check the combustion performance under real operating conditions (doors shut, cover fitted etc.). Record the results in the relevant documents.



en

Symbol	Observation	Cause	Corrective action
	The thermostat no longer starts the burner.	No heat requested by thermostats Defective control unit.	Check/replace the thermostat. Replace the control unit.
 8,00 µA 230 V 55,0 ° 0006 G 00:02:40	The burner starts up briefly when the power supply is switched on and then stops	The control unit has intentionally been manually locked.	Unlock the unit.
 8,00 µA 230 V 25,0 ° 0006 G 00:00:20	The burner starts then stops after pre-ventilation	Unauthorised flame is detected during the pre-ventilation/pre-ignition period	Check for the ignition spark/adjust the electrodes/replace Check/replace the fuel oil solenoid valve Checking/replacing the cell
 0,00 µA 230 V 25,0 ° 0006 G 00:00:30	The burner starts and stops after the solenoid valves have opened	No flame at the end of the safety time.	Check fuel oil level in tank. Top the tank up as required. Open the valves. Check the fuel oil pressure and the operation of the pump, coupling, filter and solenoid valve. Check the ignition circuit, the electrodes and their settings. Clean the electrodes. Clean and replace the cell.
 0,00 µA 230 V 35,0 ° 0006 G 00:01:20	Flame failure during operation.	The flame goes out during the operating phase	Replace the following parts as required: ignition electrodes/ignition cables/ igniter/nozzle/pump/solenoid valve/safety unit.
 0,00 µA 230 V 68,0 ° 0006 G 00:00:40	Servomotor fault	Clogging of the air flap Locking of the air flap Internal fault with the servomotor	Replace the servomotor

Fault diagnosis menu Operating statistics menu



Fault diagnosis menu

To access the fault diagnosis menu, press any button when the burner is ready to operate, when the burner is in operation, or when it is in malfunction mode. It is not possible to access the fault diagnosis menu during the start-up phase.

The general menu screen will appear. Using the buttons , , , or , place the cursor on the fault diagnosis menu symbol, and confirm using the button .

The details of the last fault to appear are indicated by the flashing symbol. The flame intensity, network voltage, air flap position, number of burner start-ups as well as the operating time of the burner at the time it switched to malfunction mode are displayed underneath.



Using the buttons and , it is possible to call up the details of the last 5 faults to have appeared (the fault number is displayed in the upper left corner of the display). After the details of the last 5 faults, the telephone number of the after-sales department as well as the maintenance contract number are shown (no values are entered in the factory).

- Quit the menu using the button .

Entering a telephone number for the maintenance company and the maintenance contract number

When the corresponding symbol appears on the display:

- Keep the button held down until the first figure starts to flash (a short press will exit the menu).
- Using the buttons or , change the figure to the value required (underscore = empty field)
- Using the button , move on to the next figure.
- When the number is complete, save using the button .



Operating statistics menu

To access the operating statistics menu, press any button, when the burner is ready to operate, when the burner is in operation, or when it is in malfunction mode. It is impossible to access the operating statistics diagnosis menu during the start-up phase.

The general menu screen will appear. Using the buttons , , , or , place the cursor on the operating statistics menu symbol, and confirm using the button .

The operating statistics menu comprises 7 screens. Navigation between the different screens is done using the buttons and .

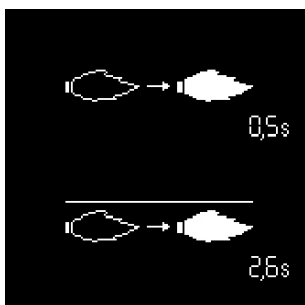

- Flame detection time for last start-up

- Average flame detection time for the latest 5 start-ups



- Total number of burner start-ups

- Total number of faults

- Total number of operating hours

- Total number of operating hours in 2nd stage

Operating statistics menu

en

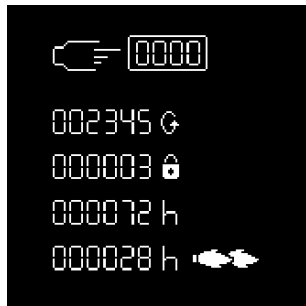

- Total number of burner start-ups since the last meter reset
- Total number of faults since the last meter reset
- Total operating time since the last meter reset
- Total operating time in 2nd stage since the last meter reset

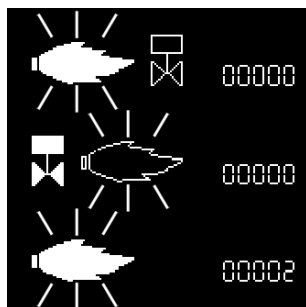

- Number of "unwanted flame" faults
- Number of "No flame after safety time" faults
- Number of "Flame loss during operation" faults

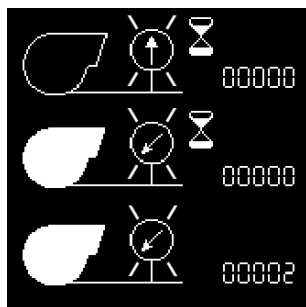

- Number of "Air pressure switch stuck" faults
- Number of "Air pressure switch does not close during operation" faults
- Number of "Air pressure switch switching over" faults

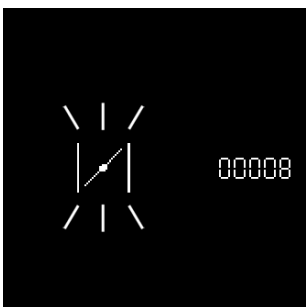

- Number of "servomotor" faults

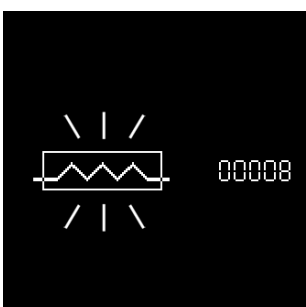

- Number of "fuel oil pre-heater" faults

- Quit the menu using the button 



www.elco.net

		Hotline
	ELCO Austria GmbH Aredstr.16-18 2544 Leobersdorf	0810-400010
	ELCO Belgium nv/sa Z.1 Researchpark 60 1731 Zellik	02-4631902
	ELCOTHERM AG Sarganserstrasse 100 7324 Vilters	0848 808 808
	ELCO GmbH Dreichstr.10 64546 Mörfelden-Walldorf	0180-3526180
	ELCO Italia S.p.A. Via Roma 64 31023 Resana (TV)	800-087887
	ELCO Burners B.V. Amsterdamsestraatweg 27 1411 AW Naarden	035-6957350
	ООО «Ariston Thermo RUS LLC» Bolshaya Novodmitrovskaya St.bld.14/1 office 626 127015 Moscow -Russia	+7 495 783 0440

Hergestellt in der EU. Fabriqué en EU. Fabricato in EU.
Angaben ohne Gewähr. Document non contractuel. Documento non contrattuale.